

TRANSNET FREIGHT RAIL

an Operating Division of **TRANSNET SOC LTD**

[hereinafter referred to as **Transnet**]

Registration Number 1990/000900/30

REQUEST FOR QUOTATION [RFQ] No ERAC_RCB_46979-NM318

FOR THE SUPPLY OF: TUNNEL EPOXY, ECCENTRIC CENTER WASHERS AND EPOXY PAN MIXER

FOR DELIVERY TO: RICHARDS BAY DEPOT

ISSUE DATE: 24 JUNE 2024

CLOSING DATE: 02 JULY 2024

CLOSING TIME: 10H00

BID VALIDITY PERIOD: 04 NOVEMBER 2024 (90 BUSINESS DAYS FROM CLOSING DATE)

Note to the bidders:

Bidders are required to ensure that electronic bid submissions are done at least a day before the closing date to prevent issues which they may encounter due to their internet speed, bandwidth or the size of the number of uploads they are submitting. Transnet will not be held liable for any challenges experienced by bidders as a result of the technical challenges. Please do not wait for the last hour to submit. A Bidder can upload 30mb per upload and multiple uploads are permitted.

SECTION 1: SBD1 FORM**PART A
INVITATION TO BID****YOU ARE HEREBY INVITED TO BID FOR REQUIREMENTS OF TRANSNET FREIGHT RAIL, A DIVISION TRANSNET SOC LTD**

BID NUMBER:	ERAC_RCB_46979-NM318	ISSUE DATE:	24 June 2024	CLOSING DATE:	02 July 2024	CLOSING TIME:	10h00am
DESCRIPTION	Supply and deliver tunnel epoxy, eccentric center washers and epoxy pan mixer to Richards Bay Depot						

BID RESPONSE DOCUMENTS SUBMISSION

This RFQ may be downloaded directly from National Treasury's e-Tender Publication Portal at www.etenders.gov.za free of charge.

To download RFQ:

- Click on "Tender Opportunities";
- Select "Advertised Tenders";
- In the "Department" box, select Transnet SOC Ltd;

Once the tender has been located in the list, click on the "Tender documents" tab and process to download all uploaded documents.

- The RFQ may also be downloaded from the Transnet website at <https://transnetetenders.azurewebsites.net> (please use **Google Chrome** to access Transnet link/site) free of charge (*refer to section 2, paragraph 3 below for detailed steps*).

BIDDING PROCEDURE ENQUIRIES MAY BE DIRECTED TO**TECHNICAL ENQUIRIES MAY BE DIRECTED TO:**

CONTACT PERSON	Zonke Mdletshe	CONTACT PERSON	Zonke Mdletshe
TELEPHONE NUMBER	N/A	TELEPHONE NUMBER	N/A
FACSIMILE NUMBER	N/A	FACSIMILE NUMBER	N/A
E-MAIL ADDRESS	Zonke.Mdletshe@transnet.net	E-MAIL ADDRESS	Zonke.Mdletshe@transnet.net

SUPPLIER INFORMATION

NAME OF BIDDER					
POSTAL ADDRESS					
STREET ADDRESS					
TELEPHONE NUMBER	CODE		NUMBER		
CELLPHONE NUMBER					
FACSIMILE NUMBER	CODE		NUMBER		
E-MAIL ADDRESS					
VAT REGISTRATION NUMBER					
SUPPLIER COMPLIANCE STATUS	TAX COMPLIANCE SYSTEM PIN:		OR	CENTRAL SUPPLIER DATABASE	UNIQUE REGISTRATION REFERENCE NUMBER: MAAA
B-BBEE STATUS LEVEL VERIFICATION CERTIFICATE	TICK APPLICABLE BOX] <input type="checkbox"/> Yes <input type="checkbox"/> No		B-BBEE STATUS LEVEL SWORN AFFIDAVIT	[TICK APPLICABLE BOX] <input type="checkbox"/> Yes <input type="checkbox"/> No	

[A B-BBEE STATUS LEVEL VERIFICATION CERTIFICATE/ SWORN AFFIDAVIT MUST BE SUBMITTED FOR PURPOSES OF COMPLIANCE WITH THE B-BBEE ACT]

<p>1 ARE YOU THE ACCREDITED REPRESENTATIVE IN SOUTH AFRICA FOR THE GOODS /SERVICES /WORKS OFFERED?</p>	<p><input type="checkbox"/>Yes <input type="checkbox"/>No</p> <p>[IF YES ENCLOSE PROOF]</p>	<p>2 ARE YOU A FOREIGN BASED SUPPLIER FOR THE GOODS /SERVICES /WORKS OFFERED?</p>	<p><input type="checkbox"/>Yes <input type="checkbox"/>No</p> <p>[IF YES, ANSWER QUESTIONNAIRE BELOW]</p>
---	---	--	--

QUESTIONNAIRE TO BIDDING FOREIGN SUPPLIERS

IS THE ENTITY A RESIDENT OF THE REPUBLIC OF SOUTH AFRICA (RSA)?	<input type="checkbox"/> YES <input type="checkbox"/> NO
DOES THE ENTITY HAVE A BRANCH IN THE RSA?	<input type="checkbox"/> YES <input type="checkbox"/> NO
DOES THE ENTITY HAVE A PERMANENT ESTABLISHMENT IN THE RSA?	<input type="checkbox"/> YES <input type="checkbox"/> NO
DOES THE ENTITY HAVE ANY SOURCE OF INCOME IN THE RSA?	<input type="checkbox"/> YES <input type="checkbox"/> NO
IS THE ENTITY LIABLE IN THE RSA FOR ANY FORM OF TAXATION?	<input type="checkbox"/> YES <input type="checkbox"/> NO

IF THE ANSWER IS "NO" TO ALL OF THE ABOVE, THEN IT IS NOT A REQUIREMENT TO REGISTER FOR A TAX COMPLIANCE STATUS SYSTEM PIN CODE FROM THE SOUTH AFRICAN REVENUE SERVICE (SARS) AND IF NOT REGISTER AS PER 1.3 BELOW.

**PART B
TERMS AND CONDITIONS FOR BIDDING**

1. TAX COMPLIANCE REQUIREMENTS
<p>1.1 BIDDERS MUST ENSURE COMPLIANCE WITH THEIR TAX OBLIGATIONS.</p> <p>1.2 BIDDERS ARE REQUIRED TO SUBMIT THEIR UNIQUE PERSONAL IDENTIFICATION NUMBER (PIN) ISSUED BY SARS TO ENABLE THE ORGAN OF STATE TO VERIFY THE TAXPAYER'S PROFILE AND TAX STATUS.</p> <p>1.3 APPLICATION FOR TAX COMPLIANCE STATUS (TCS) PIN MAY BE MADE VIA E-FILING THROUGH THE SARS WEBSITE WWW.SARS.GOV.ZA.</p> <p>1.4 BIDDERS MAY ALSO SUBMIT A PRINTED TCS CERTIFICATE TOGETHER WITH THE BID.</p> <p>1.5 IN BIDS WHERE UNINCORPORATED CONSORTIA / JOINT VENTURES / SUB-CONTRACTORS ARE INVOLVED, EACH PARTY MUST SUBMIT A SEPARATE TCS CERTIFICATE / PIN / CSD NUMBER.</p> <p>1.6 WHERE NO TCS IS AVAILABLE BUT THE BIDDER IS REGISTERED ON THE CENTRAL SUPPLIER DATABASE (CSD), A CSD NUMBER MUST BE PROVIDED.</p>

NB: FAILURE TO PROVIDE / OR COMPLY WITH ANY OF THE ABOVE PARTICULARS MAY RENDER THE BID INVALID.

SIGNATURE OF BIDDER:

CAPACITY UNDER WHICH THIS BID IS SIGNED:

(Proof of authority must be submitted e.g. company resolution)

DATE:_____

SECTION 2: NOTICE TO BIDDERS

1 Responses to RFQ

Responses to this RFQ [**Quotations**] must not include documents or reference relating to any other quotation or proposal. Any additional conditions must be embodied in an accompanying letter.

DESCRIPTION	Supply and deliver tunnel epoxy, eccentric center washers and epoxy pan mixer to Richards Bay Depot (The Goods)
TENDER ADVERT	All Transnet tenders are advertised on the National Treasury's e-Tender Publication Portal and the Transnet website. Should one of these media (i.e. National Treasury's e-Tender Publication Portal or Transnet website) not be available, bidders are advised to check on the other media for advertised tenders.
RFQ DOWNLOADING	<p>This RFQ may be downloaded directly from National Treasury's e-Tender Publication Portal at www.etenders.gov.za free of charge.</p> <p>To download RFQ:</p> <ul style="list-style-type: none"> ▪ Click on "Tender Opportunities"; ▪ Select "Advertised Tenders"; ▪ In the "Department" box, select Transnet SOC Ltd; <p>Once the tender has been located in the list, click on the "Tender documents" tab and process to download all uploaded documents.</p> <ul style="list-style-type: none"> ▪ The RFQ may also be downloaded from the Transnet website at https://transnetetenders.azurewebsites.net (please use Google Chrome to access Transnet link/site) free of charge (<i>refer to section 2, paragraph 3 below for detailed steps</i>).
EMAIL ADDRESS FOR COMMUNICATION	<p>Transnet will publish the outcome of this RFQ on the National Treasury e-tender portal and Transnet website with 10 days after the award has been finalised. All unsuccessful bidders have a right to request for reasons for their bid not being successful. This requested must be directed to the contact person stated in the SBD 1 form.</p> <p>Any addenda to the RFQ or clarifications will be published on the e-tender portal and Transnet website. Bidders are required to check the e-tender portal and Transnet website prior to finalising their bid submissions for any changes or clarifications to the RFQ.</p> <p>Transnet will not be held liable if Bidders do not receive the latest information regarding this RFQ with the possible consequence of either being disadvantaged or disqualified as a result thereof.</p>
CLOSING DATE	<p>10:00am on Tuesday 02 July 2024</p> <p>Bidders must ensure that bids are uploaded onto the system against the tender. As a general rule, if a bid is late, it will not be accepted for consideration.</p> <p><i>Bidders are required to ensure that electronic bid submissions are done at least a day before the closing date to prevent issues which they may encounter due to their internet speed, bandwidth or the size of the number of uploads they are submitting. Transnet will not be held liable for any challenges experienced by bidders as a result of the technical challenges. Please do not wait for the last hour to submit. A Bidder can upload 30mb per upload and multiple uploads are permitted.</i></p>
VALIDITY PERIOD	<p>90 (Ninety) Business from Closing Date End of validity period: 04 November 2024</p> <p><i>NOTE - Bidders may be requested to extend the validity period of their bid, on the same terms and conditions, if the internal evaluation process has not been finalised within the validity period. However, once the adjudication body has approved the process and award of the business to the successful bidder(s), the validity of the successful bidder(s)' bid will be deemed to remain valid until a final contract has been concluded.</i></p> <p><i>With regard to the validity period of short-listed bidders, please refer to Section 1</i></p>

2 Formal Briefing

A formal briefing session will not be held but should Respondents have specific queries they should email these to the Transnet employee(s) indicated in paragraph 3 [Communication] below:

3 PROPOSAL SUBMISSION

Transnet has implemented a new electronic tender submission system, the e-Tender Submission Portal, in line with the overall Transnet digitalization strategy where suppliers can view advertised tenders, register their information, log their intent to respond to bids and upload their bid proposals/responses on to the system.

a) The Transnet e-Tender Submission Portal can be accessed as follows:

- Log on to the Transnet eTenders management platform website/ Portal (transnetetenders.azurewebsites.net) Please use **Google Chrome** to access Transnet link/site)
- Click on "ADVERTISED TENDERS" to view advertised tenders;
- Click on "SIGN IN/REGISTER – for bidder to register their information (must fill in all mandatory information);
- Click on "SIGN IN/REGISTER" - to sign in if already registered;
- Toggle (click to switch) the "Log an Intent" button to submit a bid;
- Submit bid documents by uploading them into the system against each tender selected.
- No late submissions will be accepted. The bidder guide can be found on the Transnet Portal transnetetenders.azurewebsites.net

4 Communication

4.1 Specific queries relating to this RFQ before the closing date of the RFQ should be submitted onto the system and to [Zonke – Zonke.Mdletshe@transnet.net] before **12:00 pm on 28 June 2024**. In the interest of fairness and transparency Transnet's response to such a query will then be made available to other bidders.

4.2 It is prohibited for Respondents to attempt, either directly or indirectly, to canvass any officer or employee of Transnet in respect of this RFQ between the closing date and the date of the award of the business.

4.3 Respondents found to be in collusion with one another will be automatically disqualified and restricted from doing business with organs of state for a specified period.

4.4 Respondents may also, at any time after the closing date of the RFQ, communicate with Ntombi Mdhuli on any matter relating to its RFQ response:

Telephone 012 315 4119

Email: Ntombikayise.Mdhuli@transnet.net

4.5 All unsuccessful bidders have a right to request Transnet to furnish individual reasons for their bid not being successful. This requested must be directed to the contact person stated in the SBD 1 form

5 Legal Compliance

The successful Respondent shall be in full and complete compliance with any and all applicable national and local laws and regulations.

6 Employment Equity Act

Respondents must comply with the requirements of the Employment Equity Act 55 of 1998 applicable to it including (but not limited to) Section 53 of the Employment Equity Act.

7 Changes to Quotations

Changes by the Respondent to its submission will not be considered after the closing date and time.

8 Binding Offer

Any Quotation furnished pursuant to this Request shall be deemed to be an offer. Any exceptions to this statement must be clearly and specifically indicated.

9 Disclaimers

9.1 Respondents are hereby advised that Transnet is not committed to any course of action as a result of its issuance of this RFQ and/or its receipt of a Quotation in response to it. Please note that Transnet reserves the right to:

- modify the RFQ's goods / service(s) and request Respondents to re-bid on any changes;
- reject any Quotation which does not conform to instructions and specifications which are detailed herein;
- disqualify Quotations submitted after the stated submission deadline;
- not necessarily accept the lowest priced Quotation or an alternative bid;
- place an order in connection with this Quotation at any time after the RFQ's closing date;
- award only a portion of the proposed goods / services which are reflected in the scope of this RFQ;
- split the award of the order/s between more than one Supplier/Service Provider should it at Transnet's discretion be more advantageous in terms of, amongst others, cost or developmental considerations;
- cancel the quotation process;
- validate any information submitted by Respondents in response to this bid. This would include, but is not limited to, requesting the Respondents to provide supporting evidence. By submitting a bid, Respondents hereby irrevocably grant the necessary consent to Transnet to do so;
- request audited financial statements or other documentation for the purposes of a due diligence exercise;
- not accept any changes or purported changes by the Respondent to the bid rates after the closing date and/or after the award of the business, unless the contract specifically provides for it;
- to cancel the contract and/request that National Treasury place the Respondent on its Database of Restricted Suppliers for a period not exceeding 10 years, on the basis that a contract was awarded on the strength of incorrect information furnished by the Respondent or on any other basis recognised in law;
- award the business to the next ranked bidder, provided that he/she is still prepared to provide the required Goods/Services at the quoted price, should the preferred bidder fail to sign or commence with the contract within a reasonable period after being requested to do so. Under such circumstances, the validity of the bids of the next ranked bidder(s) will be deemed to remain valid, irrespective of whether the next ranked bidder(s) were notified of their bid being unsuccessful. Bidders may therefore be requested to advise whether they would still be prepared to provide the required Goods/Services at their quoted price.
- Should a bidder fail to respond to a request for extension of the validity period before it expires, that bidder will be excluded from tender process.

10 Specification/Scope of Work

Section 4: Quotation form

11 Legal review

A Proposal submitted by a Respondent will be subjected to review and acceptance or rejection of its proposed contractual terms and conditions by Transnet's Legal Counsel, prior to consideration for an award of business.

12 Security clearance

Acceptance of this bid could be subject to the condition that the Successful Respondent, its personnel providing the goods and its subcontractor(s) must obtain security clearance from the appropriate authorities to the level of CONFIDENTIAL/ SECRET/TOP SECRET. Obtaining the required clearance is the responsibility of the Successful Respondent. Acceptance of the bid is also subject to the condition that the Successful Respondent will implement all such security measures as the safe performance of the contract may require.

13 National Treasury’s Central Supplier Database

Respondents are required to self-register on National Treasury’s Central Supplier Database (CSD) which has been established to centrally administer supplier information for all organs of state and facilitate the verification of certain key supplier information. Transnet is required to ensure that price quotations are invited and accepted from prospective bidders listed on the CSD. Business may not be awarded to a respondent who has failed to register on the CSD. Only foreign suppliers with no local registered entity need not register on the CSD. The CSD can be accessed at <https://secure.csd.gov.za/>.

14 Tax Compliance

Respondents must be compliant when submitting a proposal to Transnet and remain compliant for the entire contract term with all applicable tax legislation, including but not limited to the Income Tax Act, 1962 (Act No. 58 of 1962) and Value Added Tax Act, 1991 (Act No. 89 of 1991).

It is a condition of this bid that the tax matters of the successful Respondents be in order, or that satisfactory arrangements have been made with South African Revenue Service (SARS) to meet the Respondents tax obligations.

The Tax Compliance status requirements are also applicable to foreign Respondents/ individuals who wish to submit bids.

Where Consortia / Joint Ventures / Sub-contractors are involved, each party must be registered on the Central Supplier Database and their tax compliance status will be verified through the Central Supplier Database.

Transnet urges its clients, suppliers and the general public to report any fraud or corruption to

TIP-OFFS ANONYMOUS:



You can choose to be Anonymous or Non-Anonymous on ANY of the platforms
PLEASE RETAIN YOUR REFERENCE NUMBER

 <p>AI Voice Bot “Jack” Speak to our AI Voice Chat Bot “JACK”, you converse with him like chatting to a human, with the option to record a message and speak to an agent at anytime.</p>	 <p>What’s App Speak to an Agent via What’s App.</p>	 <p>Speak to an Agent Speak to an Agent via the platform with no call or data charge</p>	 <p>Telegram Speak to an Agent via Telegram</p>
 0800 003 056	 086 551 4153	 reportit@ethicshelpdesk.com	 *120*0785980808#

SECTION 3 EVALUATION METHODOLOGY, CRITERIA AND RETURNABLE DOCUMENTS

1 Evaluation Criteria

Transnet will utilise the following methodology and criteria in selecting a preferred Supplier/Service provider:

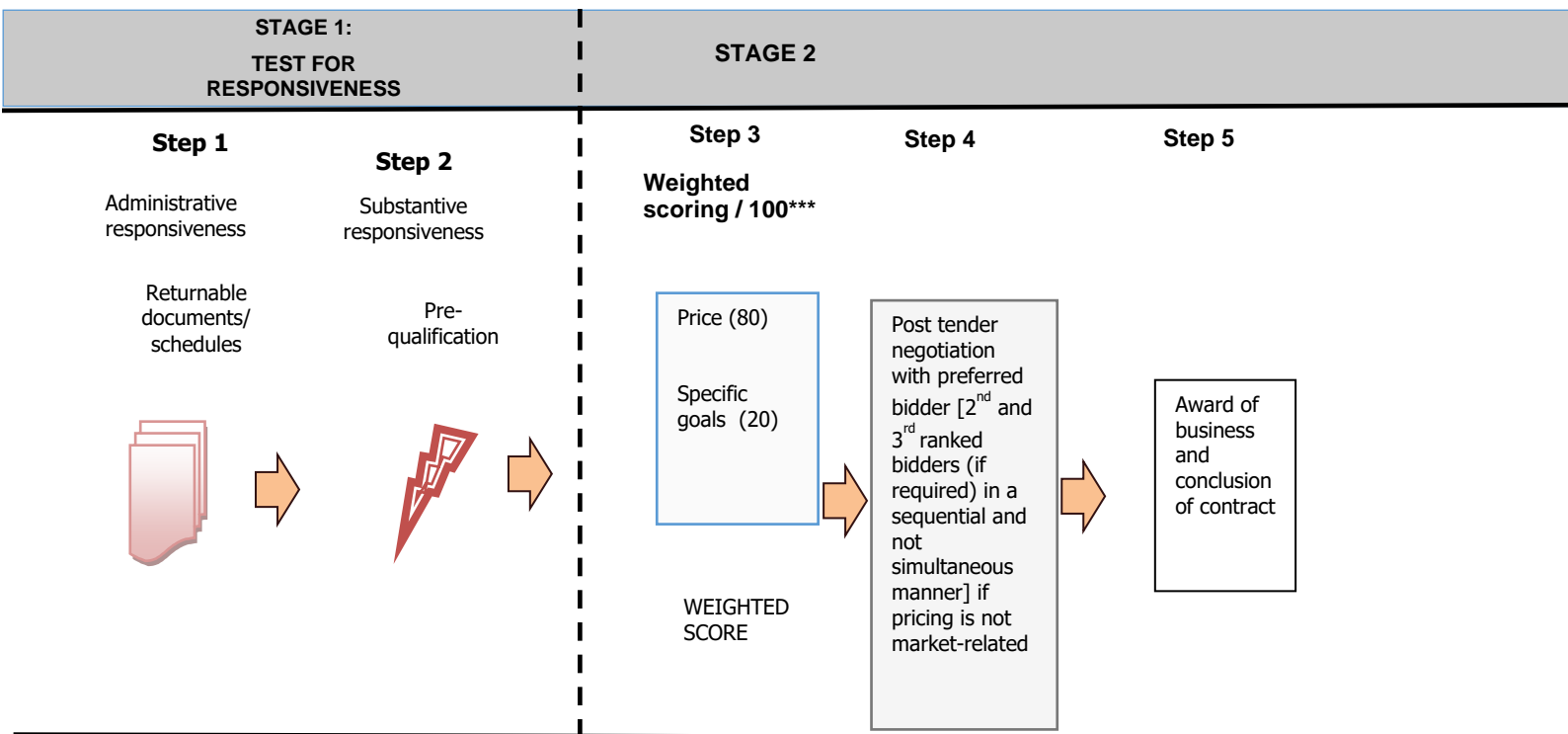

1.1 STEP ONE: Test for Administrative Responsiveness

The test for administrative responsiveness will include the following:

Administrative responsiveness check	RFQ Reference
<ul style="list-style-type: none"> Whether the Bid has been lodged on time 	
<ul style="list-style-type: none"> Whether all Returnable Documents and/or schedules [where applicable] were completed and returned by the closing date and time 	<i>Section 3</i>
<ul style="list-style-type: none"> Verify the validity of all returnable documents 	<i>Section 3</i>
<ul style="list-style-type: none"> Verify if the Bid document has been duly signed by the authorised respondent 	<i>All sections</i>

The test for administrative responsiveness [Step One] must be passed for a Respondent's Proposal to progress to Step Two for further pre-qualification

1.2 STEP TWO: Test for Substantive Responsiveness to RFQ

The test for substantive responsiveness to this RFQ will include the following:

Check for substantive responsiveness	RFQ Reference
<ul style="list-style-type: none"> Whether any general and legislation qualification criteria set by Transnet, have been met 	<i>All sections</i>
<ul style="list-style-type: none"> Whether the Bid contains a priced offer 	<i>Section 4 - Quotation Form</i>

The test for substantive responsiveness [Step Two] must be passed for a Respondent's proposal to progress to Step Three for further evaluation

1.3 STEP THREE: Evaluation and Final Weighted Scoring

a) **Price and TCO Criteria** [Weighted score 80 points]:

Evaluation Criteria	RFP Reference
<ul style="list-style-type: none"> • Commercial offer 	<p><i>Section 4</i></p>

$$PS = 80 \left(1 - \frac{Pt - Pmin}{Pmin} \right)$$

Where:

Ps = Points scored for the price of Bid under consideration

Pt = Price of Bid under consideration

Pmax = Price of highest acceptable Bid

b) **Specific Goals** [Weighted score 20 point]

- Specific goals claim form
- Preference points will be awarded to a bidder for attaining the specific goals requirements in accordance with the table indicated in Section 7, paragraph 3.2 of the specific goals Claim Form.

1.4 STEP FOUR: Post Tender Negotiations (if applicable)

- Respondents are to note that Transnet may not award a contract if the price offered is not market-related. In this regard, Transnet reserves the right to engage in PTN with the view to achieving a market-related price or to cancel the tender. Negotiations will be done in a sequential manner i.e.:
 - first negotiate with the highest ranked bidder or cancel the bid, should such negotiations fail,
 - negotiate with the 2nd and 3rd ranked bidders (if required) in a sequential manner.
- In the event of any Respondent being notified of such short-listed/preferred bidder status, his/her bid, as well as any subsequent negotiated best and final offers (BAFO), will automatically be deemed to remain valid during the negotiation period and until the ultimate award of business.
- Should Transnet conduct post tender negotiations, Respondents will be requested to provide their best and final offers to Transnet based on such negotiations. Where a market related price has been achieved through negotiation, the contract will be awarded to the successful Respondent(s).

1.5 STEP FIVE: Award of business and conclusion of contract

- Immediately after approval to award the contract has been received, the successful or preferred bidder(s) will be informed of the acceptance of his/their Quotation by way of a Letter of Award. Thereafter the final contract will be concluded with the successful Respondent(s).
- Otherwise, a final contract will be concluded and entered into with the successful Bidder at the acceptance of a letter of award by the Respondent.

2 Validity Period

Transnet requires a validity period of 90 [ninety] Business Days – 04 November 2024 from the closing date of this RFQ, excluding the first day and including the last day.

Bidders are to note that they may be requested to extend the validity period of their bid, on the same terms and conditions, if the internal evaluation process has not been finalised within the validity period. However, once the adjudication body has approved the process and award of the business to the successful bidder(s), the validity of the successful bidder(s)' bid will be deemed to remain valid until a final contract has been concluded.

3 Disclosure of contract information

Johannesburg Stock Exchange Debt Listing Requirements

Transnet may also be required to disclose information relating to the subsequent contract i.e. the name of the company, goods/services provided by the company, the value and duration of the contract, etc. in compliance with the Johannesburg Stock Exchange (JSE) Debt Listing Requirements.

Domestic Prominent Influential Persons (DPIP) OR Foreign Prominent Public Officials (FPPO)

Transnet is free to procure the services of any person within or outside the Republic of South Africa in accordance with applicable legislation. Transnet shall not conduct or conclude business transactions, with any Respondents without having:

- Considered relevant governance protocols;
- Determined the DPIP or FPPO status of that counterparty; and
- Conducted a risk assessment and due diligence to assess the potential risks that may be posed by the business relationship.

As per the Transnet Domestic Prominent Influential Persons (DPIP) and Foreign Prominent Public Officials (FPPO) and Related Individuals Policy available on Transnet website <https://www.transnet.net/search/pages/results.aspx?k=FPIDP#k=DPIP>, Respondents are required to disclose any commercial relationship with a DPIP or FPPO (as defined in the Policy) by completing the following section:

The below form contains personal information as defined in the Protection of Personal Information Act, 2013 (the "Act"). By completing the form, the signatory consents to the processing of her/his personal information in accordance with the requirements of the Act. Consent cannot unreasonably be withheld.						
Is the Respondent <i>(Complete with a "Yes" or "No")</i>						
A DPIP/FPPO		Closely Related to a DPIP/FPPO		Closely Associated to a DPIP/FPPO		
List all known business interests, in which a DPIP/FPPO may have a direct/indirect interest or significant participation or involvement.						
No	Name of Entity / Business	Role in the Entity / Business (Nature of interest/ Participation)	Shareholding %	Registration Number	Status (Mark the applicable option with an X)	
					Active	Non-Active
1						
2						

Returnable Document

Respondents declaring a commercial relationship with a DPIP or FPPO are to note that Transnet is required to annually publish on its website a list of all business contracts entered into with DPIP or FPPO. This list will include successful Respondents, if applicable.

4 Returnable Documents

Returnable Documents means all the documents, Sections and Annexures, as listed in the tables below. There are three types of returnable documents as indicated below and Respondents are urged to ensure that these documents are returned with their bids based on the consequences of non-submission as indicated below:

Mandatory Returnable Documents	<i>Failure to provide all these Mandatory Returnable Documents at the Closing Date and time of this RFQ <u>will</u> result in a Respondent's disqualification.</i>
Returnable Documents Used for Scoring	<i>Failure to provide all Returnable Documents used for purposes of scoring a bid, by the closing date and time of this bid will not result in a Respondent's disqualification. However, Bidders will receive an automatic score of zero for the applicable evaluation criterion.</i>
Essential Returnable Documents	<i>Failure to provide essential Returnable Documents <u>will</u> result in Transnet affording Respondents a further opportunity to submit by a set deadline. Should a Respondent thereafter fail to submit the requested documents, this may result in a Respondent's disqualification.</i>

All Returnable Sections, as indicated in the header and footer of the relevant pages, must be signed, stamped and dated by the Respondent.

a) Mandatory Returnable Documents

Respondents are required to submit with their bid submissions the following **Mandatory Returnable Documents**, and also to confirm submission of these documents by so indicating [Yes or No] in the tables below:

Mandatory Returnable Documents	Submitted [Yes or No]
SECTION 4 : Quotation Form	

b) Returnable Documents Used for Scoring

In addition to the requirements of section (a) above, Respondents are further required to submit with their Proposals the following **Returnable Documents Used for Scoring** and also to confirm submission of these documents by so indicating [Yes or No] in the table below:

RETURNABLE DOCUMENTS USED FOR SCORING	SUBMITTED [Yes or No]
Respondent's valid proof of evidence to claim points for compliance with Specific Goals' requirements as stipulated in Section 7 of this RFQ	
B-BBEE Certificate / Sworn- Affidavit / B-BBEE CIPC Certificate (in case of JV, a consolidated scorecard will be accepted) as per DTIC guideline	

c) Essential Returnable Documents:

Over and the above the requirements of section (a) and (b) mentioned above, Respondents are further required to submit with their Proposals the following **Essential Returnable Documents** and also to confirm submission of these documents by so indicating [Yes or No] in the table below:

ESSENTIAL RETURNABLE DOCUMENTS & SCHEDULES	SUBMITTED [Yes or No]
SECTION 1: SBD1 Form	
SECTION 3: Evaluation Methodology, Criteria and Returnable Documents	
SECTION 5: Certificate of Acquaintance with RFQ Documents	
SECTION 6: RFQ Declaration and Breach of Law Form	
SECTION 7: B-BBEE Preference Claim Form	
SECTION 8: Protection of Personal Information	
CSD Registration report	

5 CONTINUED VALIDITY OF RETURNABLE DOCUMENTS

The successful Respondent will be required to ensure the validity of all returnable documents, including but not limited to its valid proof of B-BBEE status, for the duration of any contract emanating from this RFQ. Should the Respondent be awarded the contract [**the Agreement**] and fail to present Transnet with such renewals as and when they become due, Transnet shall be entitled, in addition to any other rights and remedies that it may have in terms of the eventual Agreement, to terminate such Agreement immediately without any liability and without prejudice to any claims which Transnet may have for damages against the Respondent.

SECTION 4

QUOTATION FORM

I/We _____

hereby offer to supply the goods/services at the prices quoted in the Price Schedule below, in accordance with the conditions related thereto.

I/We agree to be bound by those terms and conditions in:

- the Standard RFQ Terms and Conditions for the Supply of Goods or Services to Transnet; and
- any other standard or special conditions embodied in this Request for Quotation.

I/We accept that unless Transnet should otherwise decide and so inform me/us, this Quotation [and, if any, its covering letter and any subsequent exchange of correspondence], together with Transnet's acceptance thereof shall constitute a binding contract between Transnet and me/us. I/We further agree that if, after I/we have been notified of the acceptance of my/our Quotation, I/we fail to deliver the said goods/service/s within the delivery lead-time quoted, Transnet may, without prejudice to any other legal remedy which it may have, cancel the order and recover from me/us any expenses incurred by Transnet in calling for Quotations afresh and/or having to accept any less favourable offer.

Price Schedule

I/We quote as follows for the goods/services required, on a "delivered nominated destination – Richards Bay" basis, including VAT:

Item No	Description of Item	Quantity	Unit	Rate	TOTAL PRICE OF ITEM [ZAR]
1	Tunnel Epoxy (3 Litres) Annexure A	800	Each		
2	Eccentric centre washers Refer to Annexure B	800	Each		
3	Epoxy pan mixer Refer to Annexure C	2	Each		
TOTAL PRICE, exclusive of VAT:					
VAT 15% (if applicable)					
Total Inclusive of VAT (where applicable)					

Delivery Lead-Time from date of purchase order: _____ **[days/weeks]**

Respondents are to note that Transnet will round off final pricing scores to the nearest 2 (two) decimal places.

Notes to Pricing:

- a) Respondents are to note that if the price offered by the highest scoring bidder is not market-related, Transnet may not award the contract to that Respondent. Transnet may-
 - (i) negotiate a market-related price with the Respondent scoring the highest points or cancel the RFQ;
 - (ii) if that Respondent does not agree to a market-related price, negotiate a market-related price with the Respondent scoring the second highest points or cancel the RFQ;

Respondent's Signature

Date & Company Stamp

(iii) if the Respondent scoring the second highest points does not agree to a market-related price, negotiate a market-related price with the Respondent scoring the third highest points or cancel the RFQ.

If a market-related price is not agreed with the Respondent scoring the third highest points, Transnet must cancel the RFQ.

- b) All Prices must be quoted in South African Rand, Exclusive of VAT
- c) Any disbursement not specifically priced for will not be considered/accepted by Transnet.
- d) To facilitate like-for-like comparison bidders must submit pricing strictly in accordance with this price schedule and not utilise a different format. Deviation from this pricing schedule could result in a bid being disqualified.
- e) Please note that should you have offered a discounted price(s), Transnet will only consider such price discount(s) in the final evaluation stage if offered on an unconditional basis.

**SECTION 5
 CERTIFICATE OF ACQUAINTANCE WITH RFQ DOCUMENTS**

By signing this certificate the Respondent is deemed to acknowledge that he/she has made himself/herself thoroughly familiar with, and agrees with all the conditions governing this RFQ. This includes those terms and conditions contained in any printed form stated to form part hereof, including but not limited to the documents stated below. As such, Transnet will recognise no claim for relief based on an allegation that the Respondent overlooked any such term or condition or failed properly to take it into account in calculating tendered prices or any other purpose:

1. Transnet’s General Bid Conditions
2. Standard RFQ Terms and Conditions for the supply of Goods or Services to Transnet
3. Transnet’s Supplier Integrity Pact
4. Non-disclosure Agreement

Note: Should a Respondent be successful and awarded the bid, they will be required to complete a Supplier Declaration Form for registration as a vendor onto the Transnet vendor master database.

Should the Bidder find any terms or conditions stipulated in any of the relevant documents quoted in the RFQ unacceptable, it should indicate which conditions are unacceptable and offer alternatives by written submission on its company letterhead, attached to its submitted Bid. Any such submission shall be subject to review by Transnet’s Legal Counsel who shall determine whether the proposed alternative(s) are acceptable or otherwise, as the case may be. A material deviation from the Standard terms or conditions could result in disqualification.

Bidders accept that an obligation rests on them to clarify any uncertainties regarding any bid to which they intend to respond, before submitting the bid. The Bidder agrees that he/she will have no claim or cause of action based on an allegation that any aspect of this RFQ was unclear but in respect of which he/she failed to obtain clarity.

The bidder understands that his/her Bid will be disqualified if this Certificate of Acquaintance with RFQ documents included in the RFQ as a returnable document, is found not to be true and/ or complete in every respect.

SIGNED at _____ on this ____ day of _____ 20__

SIGNATURE OF WITNESSES

ADDRESS OF WITNESSES

1 _____
 Name _____

2 _____
 Name _____

SIGNATURE OF RESPONDENT’S AUTHORISED REPRESENTATIVE: _____

NAME: _____

DESIGNATION: _____

SECTION 6
RFQ DECLARATION AND BREACH OF LAW FORM

NAME OF ENTITY: _____

We _____ do hereby certify that:

1. Transnet has supplied and we have received appropriate responses to any/all questions [as applicable] which were submitted by ourselves for RFQ Clarification purposes;
2. We have received all information we deemed necessary for the completion of this Request for Quotation [**RFQ**];
3. We have been provided with sufficient access to the existing Transnet facilities/sites and all relevant information relevant to the Supply of the Goods as well as Transnet information and Employees, and have had sufficient time in which to conduct and perform a thorough due diligence of Transnet's operations and business requirements and assets used by Transnet. Transnet will therefore not consider or permit any pre- or post-contract verification or any related adjustment to pricing, service levels or any other provisions/conditions based on any incorrect assumptions made by the Respondent in arriving at his Bid Price.
4. At no stage have we received additional information relating to the subject matter of this RFQ from Transnet sources, other than information formally received from the designated Transnet contact(s) as nominated in the RFQ documents;
5. We have complied with all obligations of the Bidder/Supplier as indicated in the Transnet Supplier Integrity Pact which includes but are not limited to ensuring that we take all measures necessary to prevent corrupt practices, unfairness and illegal activities in order to secure or in furtherance to secure a contract with Transnet;
6. We are satisfied, insofar as our entity is concerned, that the processes and procedures adopted by Transnet in issuing this RFQ and the requirements requested from Bidders in responding to this RFQ have been conducted in a fair and transparent manner;
7. We declare that a family, business and/or social relationship **exists / does not exist** [delete as applicable] between an owner / member / director / partner / shareholder of our entity and an employee or board member of Transnet including any person who may be involved in the evaluation and/or adjudication of this Bid;
8. We declare that an owner / member / director / partner / shareholder of our entity **is / is not** [delete as applicable] an employee or board member of the Transnet;
9. In addition, we declare that an owner / member / director / partner / shareholder/employee of our entity **has / has not been** [delete as applicable] a former employee or board member of Transnet in the past 10 years. I further declare that if they were a former employee or board member of Transnet in the past 10 years that they **were/were not** involved in the bid preparation or had access to the information related to this RFQ; and
10. If such a relationship as indicated in paragraph 7, 8 and/or 9 exists, the Respondent is to complete the following section:

FULL NAME OF OWNER/MEMBER/DIRECTOR/
PARTNER/SHAREHOLDER/EMPLOYEE:

ADDRESS:

Indicate nature of relationship with Transnet:

[Failure to furnish complete and accurate information in this regard will lead to the disqualification of a response and may preclude a Respondent from doing future business with Transnet]. Information provided in the declarations may be used by Transnet and/or its affiliates to verify the correctness of the information provided.

11. We declare, to the extent that we are aware or become aware of any relationship between ourselves and Transnet [other than any existing and appropriate business relationship with Transnet] which could unfairly advantage our entity in the forthcoming adjudication process, we shall notify Transnet immediately in writing of such circumstances.

BIDDER’S DISCLOSURE (SBD4)

12 PURPOSE OF THE FORM

12.1 Any person (natural or juristic) may make an offer or offers in terms of this invitation to bid. In line with the principles of transparency, accountability, impartiality, and ethics as enshrined in the Constitution of the Republic of South Africa and further expressed in various pieces of legislation, it is required for the bidder to make this declaration in respect of the details required hereunder.

12.2 Where a person/s are listed in the Register for Tender Defaulters and / or the List of Restricted Suppliers, that person will automatically be disqualified from the bid process.

13 Bidder’s declaration

13.1 Is the bidder, or any of its directors / trustees / shareholders / members / partners or any person having a controlling interest¹ in the enterprise, employed by the state?

YES/NO

13.1.1. If so, furnish particulars of the names, individual identity numbers, and, if applicable, state employee numbers of sole proprietor/ directors / trustees / shareholders / members/ partners or any person having a controlling interest in the enterprise, in table below.

Full Name	Identity Number	Name of State institution

¹ the power, by one person or a group of persons holding the majority of the equity of an enterprise, alternatively, the person/s having the deciding vote or power to influence or to direct the course and decisions of the enterprise.

13.2 Do you, or any person connected with the bidder, have a relationship with any person who is employed by the procuring institution?

YES/NO

13.2.1. If so, furnish particulars:

.....
.....

13.3 Does the bidder or any of its directors / trustees / shareholders / members / partners or any person having a controlling interest in the enterprise have any interest in any other related enterprise whether or not they are bidding for this contract?

YES/NO

13.3.1. If so, furnish particulars:

.....
.....

14 DECLARATION

I, the undersigned, (name)..... in submitting the accompanying bid, do hereby make the following statements that I certify to be true and complete in every respect:

- 14.1 I have read and I understand the contents of this disclosure;
- 14.2 I understand that the accompanying bid will be disqualified if this disclosure is found not to be true and complete in every respect;
- 14.3 The bidder has arrived at the accompanying bid independently from, and without consultation, communication, agreement or arrangement with any competitor. However, communication between partners in a joint venture or consortium² will not be construed as collusive bidding.
- 14.4 In addition, there have been no consultations, communications, agreements or arrangements with any competitor regarding the quality, quantity, specifications, prices, including methods, factors or formulas used to calculate prices, market allocation, the intention or decision to submit or not to submit the bid, bidding with the intention not to win the bid and conditions or delivery particulars of the products or services to which this bid invitation relates.
- 14.5 The terms of the accompanying bid have not been, and will not be, disclosed by the bidder, directly or indirectly, to any competitor, prior to the date and time of the official bid opening or of the awarding of the contract.
- 14.6 There have been no consultations, communications, agreements or arrangements made by the bidder with any official of the procuring institution in relation to this procurement process prior to and during the bidding process except to provide clarification on the bid submitted where so required by the institution; and the bidder was not involved in the drafting of the specifications or terms of reference for this bid.

² Joint venture or Consortium means an association of persons for the purpose of combining their expertise, property, capital, efforts, skill and knowledge in an activity for the execution of a contract.

14.7 I am aware that, in addition and without prejudice to any other remedy provided to combat any restrictive practices related to bids and contracts, bids that are suspicious will be reported to the Competition Commission for investigation and possible imposition of administrative penalties in terms of section 59 of the Competition Act No 89 of 1998 and or may be reported to the National Prosecuting Authority (NPA) for criminal investigation and or may be restricted from conducting business with the public sector for a period not exceeding ten (10) years in terms of the Prevention and Combating of Corrupt Activities Act No 12 of 2004 or any other applicable legislation.

I CERTIFY THAT THE INFORMATION FURNISHED IN PARAGRAPHS 12, 13 and 14 ABOVE IS CORRECT.

I ACCEPT THAT THE STATE MAY REJECT THE BID OR ACT AGAINST ME IN TERMS OF PARAGRAPH 6 OF PFMA SCM INSTRUCTION 03 OF 2021/22 ON PREVENTING AND COMBATING ABUSE IN THE SUPPLY CHAIN MANAGEMENT SYSTEM SHOULD THIS DECLARATION PROVE TO BE FALSE.

BREACH OF LAW

12. We further hereby certify that *I/we have/have not been* [delete as applicable] found guilty during the preceding 5 [five] years of a serious breach of law, including but not limited to a breach of the Competition Act, 89 of 1998, by a court of law, tribunal or other administrative body. The type of breach that the Respondent is required to disclose excludes relatively minor offences or misdemeanours, e.g. traffic offences. This includes the imposition of an administrative fine or penalty.

Where found guilty of such a serious breach, please disclose:

NATURE OF BREACH:

DATE OF BREACH: _____

Furthermore, I/we acknowledge that Transnet SOC Ltd reserves the right to exclude any Respondent from the bidding process, should that person or entity have been found guilty of a serious breach of law, tribunal or regulatory obligation.

SIGNED at _____ on this _____ day of _____ 20__

For and on behalf of _____ duly authorised hereto	AS WITNESS:
Name:	Name:
Position:	Position:
Signature:	Signature:
Date:	Registration No of Company/CC _____
Place:	Registration Name of Company/CC _____

SECTION 7: SPECIFIC GOALS POINTS CLAIM FORM

This preference form must form part of all bids invited. It contains general information and serves as a claim for preference points for specific goals Contribution. Transnet will award preference points to companies who provide valid proof of evidence of as per the table below.

NB: BEFORE COMPLETING THIS FORM, BIDDERS MUST STUDY THE GENERAL CONDITIONS, DEFINITIONS AND DIRECTIVES APPLICABLE IN RESPECT OF SPECIFIC GOALS, AS PRESCRIBED IN THE PREFERENTIAL PROCUREMENT POLICY FRAMEWORK ACT, 2000.

1. GENERAL CONDITIONS

- 1.1 The following preference point systems are applicable to all bids:
 - the 80/20 system for requirements with a Rand value of up to R50 000 000 (all applicable taxes included); and
- 1.2 The value of this bid is estimated to not exceed R50 000 000 (all applicable taxes included) and therefore the 80/20 preference point system shall be applicable. Despite the stipulated preference point system, Transnet shall use the lowest acceptable bid to determine the applicable preference point system in a situation where all received acceptable bids are received outside the stated preference point system.
- 1.3 The 80/20 preference point system will be applicable to this tender.
- 1.4 Preference points for this bid shall be awarded for:
 - (a) Price;
 - (b) B-BBEE Status Level of Contribution.
 - (c) Any other specific goal determined in Transnet preferential procurement policy.
- 1.5 The maximum points for this bid are allocated as follows:

	POINTS
PRICE	80
SPECIAL GOALS B-BBEE	20
B-BBEE Level of contributor (1 or 2)	10
30% Black Women Owned Entities	10
Non-Compliant and/or B-BBEE Level 3-8 contributors	0
Total points for Price and Specific Goals must not exceed	100

- 1.6 Failure on the part of a bidder to submit proof of specific goals together with the bid will be interpreted to mean that preference points for B-BBEE status level of contribution are not claimed.
- 1.7 The purchaser reserves the right to require of a bidder, either before a bid is adjudicated or at any time subsequently, to substantiate any claim in regard to preferences, in any manner required by the purchaser.

2. DEFINITIONS

- (a) **"all applicable taxes"** includes value-added tax, pay as you earn, income tax, unemployment insurance fund contributions and skills development levies;
- (b) **"B-BBEE"** means broad-based black economic empowerment as defined in section 1 of the Broad-Based Black Economic Empowerment Act;
- (c) **"B-BBEE status level of contributor"** means the B-BBEE status received by a measured entity based on its overall performance using the relevant scorecard contained in the Codes of Good Practice on Black Economic Empowerment, issued in terms of section 9(1) of the Broad-Based Black Economic Empowerment Act;

- (d) **"bid"** means a written offer in a prescribed or stipulated form in response to an invitation by an organ of state for the supply/provision of services, works or goods, through price quotations, advertised competitive bidding processes or proposals;
- (e) **"Broad-Based Black Economic Empowerment Act"** means the Broad-Based Black Economic Empowerment Act, 2003 (Act No. 53 of 2003);
- (f) **"EME"** means an Exempted Micro Enterprise as defines by Codes of Good Practice under section 9 (1) of the Broad-Based Black Economic Empowerment Act, 2003 (Act No. 53 of 2003);
- (g) **"functionality"** means the ability of a bidder to provide goods or services in accordance with specification as set out in the bid documents;
- (h) **"Price"** includes all applicable taxes less all unconditional discounts.
- (i) **"Proof of B-BBEE Status Level of Contributor"** means:
- 1) B-BBEE status level certificate issued by an unauthorised body or person;
 - 2) A sworn affidavit as prescribed by the B-BBEE Codes of Good Practice;
 - 3) Any other requirement prescribed in terms of the B-BBEE Act.
- (j) **"QSE"** means a Qualifying Small Enterprise in terms of a Codes of Good Practice under section 9 (1) of the Broad-Based Black Economic Empowerment Act, 2003 (Act No. 53 of 2003);
- (k) **"rand value"** means the total estimated value of a contract in South African currency, calculated at the time of bid invitations, and includes all applicable taxes and excise duties.
- (l) **"Specific goals"** means targeted advancement areas or categories of persons or groups either previously disadvantaged or falling within the scope of the Reconstruction and Development Programme identified by Transnet to be given preference in allocation of procurement contracts in line with section 2(1) of the PPPFA.

3. POINTS AWARDED FOR PRICE

3.1 THE 80/20 PREFERENCE POINT SYSTEMS

A maximum of 80 points is allocated for price on the following basis:

80/20

$$P_s = 80 \left(1 - \frac{P_t - P_{\min}}{P_{\min}} \right)$$

Where

P_s = Points scored for comparative price of bid under consideration

P_t = Comparative price of bid under consideration

P_{\min} = Comparative price of lowest acceptable bid

In terms of Transnet Preferential Procurement Policy (TPPP) and Procurement Manuals, the following preference points must be awarded to a bidder who provides the relevant required evidence for claiming points

Selected Specific Goal	Number of points allocated (20)
B-BBEE Level of contributor (1 or 2)	10
30% Black Women Owned Entities	10
Non-Compliant and/or B-BBEE Level 3-8 contributors	0

4. EVIDENCE REQUIRED FOR CLAIMING SPECIFIC GOALS

- 4.1 In terms of Transnet Preferential Procurement Policy (TPPP) and Procurement Manuals, preference points must be awarded to a bidder for providing evidence in accordance with the table below:

Specific Goals	Acceptable Evidence
B-BBEE	B-BBEE Certificate / Sworn- Affidavit / B-BBEE CIPC Certificate (in case of JV, a consolidated scorecard will be accepted) as per DTIC guideline
30% Black Women Owned Entities	B-BBEE Certificate / Sworn- Affidavit / B-BBEE CIPC Certificate (in case of JV, a consolidated scorecard will be accepted) as per DTIC guideline

- 4.2 The table below indicates the required proof of B-BBEE status depending on the category of enterprises:

Enterprise	B-BBEE Certificate & Sworn Affidavit
Large	Certificate issued by SANAS accredited verification agency
QSE	Certificate issued by SANAS accredited verification agency Sworn-Affidavit signed by the authorised QSE representative and attested by a Commissioner of Oaths confirming annual turnover and black ownership (only black-owned QSEs - 51% to 100% Black owned) [Sworn- affidavits must substantially comply with the format that can be obtained on the DTI's website at www.dti.gov.za/economic_empowerment/bee_codes.jsp .]
EME ³	Sworn-Affidavit signed by the authorised EME representative and attested by a Commissioner of Oaths confirming annual turnover and black ownership Certificate issued by CIPC (formerly CIPRO) confirming annual turnover and black ownership Certificate issued by SANAS accredited verification agency only if the EME is being measured on the QSE scorecard

- 4.3 A trust, consortium or joint venture (including unincorporated consortia and joint ventures) must submit a consolidated B-BBEE Status Level verification certificate for every separate bid.
- 4.4 Tertiary Institutions and Public Entities will be required to submit their B-BBEE status level certificates in terms of the specialized scorecard contained in the B-BBEE Codes of Good Practice.
- 4.5 A person will not be awarded points for B-BBEE status level if it is indicated in the bid documents that such a bidder intends sub-contracting more than 25% of the value of the contract to any other enterprise that does not qualify for at least the points that such a bidder qualifies for, unless the intended sub-contractor is an EME that has the capability and ability to execute the sub-contract.
- 4.6 A person awarded a contract may not sub-contract more than 25% of the value of the contract to any other enterprise that does not have an equal or higher B-BBEE status level than the person concerned, unless the contract is sub-contracted to an EME that has the capability and ability to execute the sub-contract.
- 4.7 Bidders are to note that the rules pertaining to B-BBEE verification and other B-BBEE requirements may be changed from time to time by regulatory bodies such as National Treasury or the DTI. It is the Bidder's responsibility to ensure that his/her bid complies fully with all B-BBEE requirements at the time of the submission of the bid.

5. BID DECLARATION

- 5.1 Bidders who claim points in respect of B-BBEE Status Level of Contribution must complete the following:

6. B-BBEE STATUS LEVEL OF CONTRIBUTION CLAIMED IN TERMS OF PARAGRAPHS 6.1

- 6.1 B-BBEE Status Level of Contribution: . = ...(based on point distribution per Table 3.2)

6.2 (Points claimed in respect of paragraph 6.1 must be in accordance with the table reflected in table 3.2 and must be substantiated by relevant proof of B-BBEE status level of contributor.

7. SUB-CONTRACTING

7.1 Will any portion of the contract be sub-contracted?

(Tick applicable box)

YES		NO	
-----	--	----	--

7.1.1 If yes, indicate:

- i) What percentage of the contract will be subcontracted.....%
- ii) The name of the sub-contractor.....
- iii) The B-BBEE status level of the sub-contractor.....
- iv) Whether the sub-contractor is an EME or QSE

(Tick applicable box)

YES		NO	
-----	--	----	--

v) Specify, by ticking the appropriate box, if subcontracting with any of the enterprises below:

Designated Group: An EME or QSE which is at last 51% owned by:	EME √	QSE √
Black people		
Black people who are youth		
Black people who are women		
Black people with disabilities		
Black people living in rural or underdeveloped areas or townships		
Cooperative owned by black people		
Black people who are military veterans		
OR		
Any EME		
Any QSE		

8. DECLARATION WITH REGARD TO COMPANY/FIRM

8.1 Name of company/firm:.....

8.2 VAT registration number:.....

8.3 Company registration number:.....

8.4 TYPE OF COMPANY/ FIRM

- Partnership/Joint Venture / Consortium
- One person business/sole propriety
- Close corporation
- Company
- (Pty) Limited

[TICK APPLICABLE BOX]

8.5 DESCRIBE PRINCIPAL BUSINESS ACTIVITIES

.....

8.6 COMPANY CLASSIFICATION

- Manufacturer
- Supplier
- Professional service provider
- Other service providers, e.g. transporter, etc.

[TICK APPLICABLE BOX]

8.7 Total number of years the company/firm has been in business:.....

8.8 I/we, the undersigned, who is / are duly authorised to do so on behalf of the company/firm, certify that the points claimed, based on the B-BBEE status level of contribution indicated in paragraph 6.1 of the foregoing certificate, qualifies the company/ firm for the preference(s) shown and I / we acknowledge that:

- i) The information furnished is true and correct;
- ii) The preference points claimed are in accordance with the General Conditions as indicated in paragraph 1 of this form;
- iii) In the event of a contract being awarded as a result of points claimed as shown in paragraph 6.1, the contractor may be required to furnish documentary proof to the satisfaction of the purchaser that the claims are correct;
- iv) If specific goals have been claimed or obtained on a fraudulent basis or any of the conditions of contract have not been fulfilled, the purchaser may, in addition to any other remedy it may have-
 - (a) disqualify the person from the bidding process;
 - (b) recover costs, losses or damages it has incurred or suffered as a result of that person's conduct;
 - (c) cancel the contract and claim any damages which it has suffered as a result of having to make less favourable arrangements due to such cancellation;
 - (d) if the successful bidder subcontracted a portion of the bid to another person without disclosing it, Transnet reserves the right to penalise the bidder up to 10 percent of the value of the contract;
 - (e) recommend that the bidder or contractor, its shareholders and directors, or only the shareholders and directors who acted on a fraudulent basis, be restricted by the National Treasury from obtaining business from any organ of state for a period not exceeding 10 years, after the *audi alteram partem* (hear the other side) rule has been applied; and
 - (f) forward the matter for criminal prosecution.

<p>WITNESSES</p> <p>1.</p> <p>2.</p>

<p>.....</p> <p>SIGNATURE(S) OF BIDDERS(S)</p> <p>DATE:</p> <p>ADDRESS</p> <p>.....</p>
--

SECTION 8**PROTECTION OF PERSONAL INFORMATION**

1. The following terms shall bear the same meaning as contemplated in Section 1 of the Protection of Person information act, No.4 of 2013. ("POPIA"):

consent; data subject; electronic communication; information officer; operator; person; personal information; processing; record; Regulator; responsible party; special information; as well as any terms derived from these terms.

2. Transnet will process all information by the Respondent in terms of the requirements contemplated in Section 4(1) of the POPIA:

Accountability; Processing limitation; Purpose specification; Further processing limitation; Information quality; Openness; Security safeguards and Data subject participation.

3. The Parties acknowledge and agree that, in relation to personal information that will be processed pursuant to this RFQ, the Responsible party is "Transnet" and the Data subject is the "Respondent". Transnet will process personal information only with the knowledge and authorisation of the Respondent and will treat personal information which comes to its knowledge as confidential and will not disclose it, unless so required by law or subject to the exceptions contained in the POPIA.
4. Transnet reserves all the rights afforded to it by the POPIA in the processing of any of its information as contained in this RFQ and the Respondent is required to comply with all prescripts as detailed in the POPIA relating to all information concerning Transnet.
5. In responding to this bid, Transnet acknowledges that it will obtain and have access to personal information of the Respondent. Transnet agrees that it shall only process the information disclosed by Respondent in their response to this bid for the purpose of evaluating and subsequent award of business and in accordance with any applicable law.
6. Transnet further agrees that in submitting any information or documentation requested in this RFQ, the Respondent is consenting to the further processing of their personal information for the purpose of, but not limited to, risk assessment, assurances, contract award, contract management, auditing, legal opinions/litigations, investigations (if applicable), document storage for the legislatively required period, destruction, de-identification and publishing of personal information by Transnet and/or its authorised appointed third parties.
7. Furthermore, Transnet will not otherwise modify, amend or alter any personal data submitted by the Respondent or disclose or permit the disclosure of any personal data to any third party without the prior written consent from the Respondent. Similarly, Transnet requires the Respondent to process any personal information disclosed by Transnet in the bidding process in the same manner.
8. Transnet shall, at all times, ensure compliance with any applicable laws put in place and maintain sufficient measures, policies and systems to manage and secure against all forms of risks to any information that may be shared or accessed pursuant to this RFQ (physically, through a computer or any other form of electronic communication).

9. Transnet shall notify the Respondent in writing of any unauthorised access to information, cybercrimes or suspected cybercrimes, in its knowledge and report such crimes or suspected crimes to the relevant authorities in accordance with applicable laws, after becoming aware of such crimes or suspected crime. The Respondent must take all necessary remedial steps to mitigate the extent of the loss or compromise of personal information and to restore the integrity of the affected personal information as quickly as is possible.
10. The Respondent may, in writing, request Transnet to confirm and/or make available any personal information in its possession in relation to the Respondent and if such personal information has been accessed by third parties and the identity thereof in terms of the POPIA. The Respondent may further request that Transnet correct (excluding critical/mandatory or evaluation information), delete, destroy, withdraw consent or object to the processing of any personal information relating to the Respondent in Transnet’s possession in terms of the provision of the POPIA and utilizing Form 2 of the POPIA Regulations.
11. In submitting any information or documentation requested in this RFQ, the Respondent is hereby consenting to the processing of their personal information for the purpose of this RFQ and further confirming that they are aware of their rights in terms of Section 5 of POPIA

Respondents are required to provide consent below:

YES		NO	
------------	--	-----------	--

12. Further, the Respondent declares that they have obtained all consents pertaining to other data subject’s personal information included in its submission and thereby indemnifying Transnet against any civil or criminal action, administrative fines or other penalty or loss that may arise as a result of the processing of any personal information that the Respondent submitted.
13. The Respondent declares that the personal information submitted for the purpose of this RFQ is complete, accurate, not misleading, is up to date and may be updated where applicable.

Signature of Respondent’s authorised representative: _____

Should a Respondent have any complaints or objections to processing of its personal information, by Transnet, the Respondent can submit a complaint to the Information Regulator on <https://www.justice.gov.za/inforeg/>, click on contact us, click on complaints.IR@justice.gov.za

ANNEXURE A – TUNNEL EPOXY

Respondent's Signature

Date & Company Stamp



A Division of Transnet SOC Limited

ICTM (TRACK TECHNOLOGY MANAGEMENT) SPECIFICATION

**User requirement specification for epoxy (tunnel
fastenings)**

BBH2474 Version 1.0

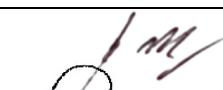
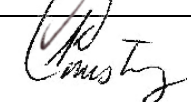
Author:	Track Technology Management		
Approved:	Senior Technologist Track Technology	J.Meyer	
Authorised:	Principal Engineer Track Technology	K.C Mistry	
Date:	May 2019		

Circulation Restricted To:

Transnet Freight Rail
Transnet and Relevant Third Parties
Unrestricted

© This document as a whole is protected by copyright. The information herein is the sole property of Transnet SOC Ltd. It may not be used, disclosed or reproduced in part or in whole in any manner whatsoever, except with the written permission of and in a manner permitted by the proprietors.



QUALITY MANAGEMENT SYSTEM

EPOXY (TUNNEL FASTENINGS)

SPECIFICATION

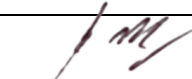
Specification number	TRL-Spec-36 (BBH2474)
Version number	1.0
Compiler name	D. de Meyer
Compiler signature	
Approver name	J. Meyer
Approver signature	

QMS SUPPORTING DOCUMENT	DOCUMENT NR: TRL-SPEC-36 (BBH2474)
	VERSION: 1.0
EPOXY (TUNNEL FASTENINGS)	DATE: 2019/05/06
	FILE REF: 16/1/17

TABLE OF CONTENTS

1	Document version.....	5
2	Purpose	5
3	Scope of specification.....	5
4	Reference documentation	5
5	Definitions and abbreviations	5
5.1	Abbreviations.....	5
5.2	Definitions	5
6	Technical requirements	6
6.1	Product approval and continued compliance	6
6.2	User requirements.....	7
6.3	Product properties.....	8
6.4	Experimental components	11
6.5	Product labelling	11
6.6	Product packaging.....	11
6.7	Warranty	11
6.8	Disposal	12
7	Quantity.....	12
8	Post purchase support.....	12
9	Documentation required	12
9.1	Procurement stage	12
9.2	Testing stage.....	12
9.3	On delivery	13
10	Delivery	13
11	Time frame	13

QMS SUPPORTING DOCUMENT	DOCUMENT NR: TRL-SPEC-36 (BBH2474)
	VERSION: 1.0
EPOXY (TUNNEL FASTENINGS)	DATE: 2019/05/06
	FILE REF: 16/1/17

12 Pre-approval and product assessment survey 13

13 Acceptance criteria..... 13

QMS SUPPORTING DOCUMENT	DOCUMENT NR: TRL-SPEC-36 (BBH2474)
	VERSION: 1.0
EPOXY (TUNNEL FASTENINGS)	DATE: 2019/05/06
	FILE REF: 16/1/17

1 DOCUMENT VERSION

This is the preliminary version of this specification.

2 PURPOSE

The purpose of this document is to supply the tenderer with the minimum technical requirements that the epoxy must comply with.

3 SCOPE OF SPECIFICATION

The scope of this specification is for the supply of epoxy. The epoxy is to become a part of the railway infrastructure and will therefore be required to carry and distribute the applied loads as well as anchor the fastening system as its primary purpose.

4 REFERENCE DOCUMENTATION

None

5 DEFINITIONS AND ABBREVIATIONS

5.1 Abbreviations

TTM - Track Technology Management

5.2 Definitions

Filling ability

The ability of fresh epoxy to flow and fill all spaces within the formwork, under its own weight. The filling ability and stability of self-compacting epoxy in the fresh state can be defined by four key characteristics namely: fluidity, passing ability, segregation and viscosity.

Fluidity

The ease of flow of fresh epoxy.

Formwork

All temporary aids and material required to support and to provide the shape of the epoxy in a structure while the epoxy is freshly mixed (Fresh), E.g. Epoxy jig.

QMS SUPPORTING DOCUMENT	DOCUMENT NR: TRL-SPEC-36 (BBH2474)
	VERSION: 1.0
EPOXY (TUNNEL FASTENINGS)	DATE: 2019/05/06
	FILE REF: 16/1/17

Passing ability

The ability of fresh epoxy to flow through tight openings such as spaces between steel reinforcing bars without segregation or blocking.

Surface finish

The quality of the visible surface in terms of its roughness and flatness after the epoxy has cured, formwork removed, and surface porosity has been exposed.

Viscosity

The resistance to flow of a material, once flow has started at a specific temperature.

6 TECHNICAL REQUIREMENTS

The following minimum technical requirements must be met.

6.1 Product approval and continued compliance

All products must be approved for use in Transnet by TTM, such approval includes laboratory testing and field testing. Testing shall be conducted by Track Technology Management and is as specified in section 6.5.

6.1.1 New products

New product approval is subject to confirmation of compliance to this specification through laboratory and field testing.

During the testing phase the suppliers shall on request supply:

- Samples
- Jigs
- Material
- Mixing equipment
- Training
- Documentation: certificates, quality assurance tests, technical information, drawings and other relevant documentation.
- Test results that indicate that the product comply with specific clauses of the specification.

QMS SUPPORTING DOCUMENT	DOCUMENT NR: TRL-SPEC-36 (BBH2474)
	VERSION: 1.0
EPOXY (TUNNEL FASTENINGS)	DATE: 2019/05/06
	FILE REF: 16/1/17

6.1.2 Currently approved products

Products that have previously been tested, approved and are currently being used by Transnet will be deemed as complying with this specification, subject to the following conditions:

- Scope of previous application is appropriate for the current intended use as outlined in this document.
- Approval has not been revoked.
- In the event of a revision of this specification approved suppliers have two years to have their product re-approved. Depending on the nature of the change re-approval may not be required.

6.1.3 Continued compliance

After approval Transnet may request samples for testing to ensure continued compliance. Such testing shall be limited to:

- 1 in every 10000 products produced
- Annually
- Upon revision of this specification
- When deemed necessary

Sample will be selected in accordance with the TTM Quality Management System procedure for Sampling (TQM-TRL-PRO-5).

6.2 User requirements

6.2.1 Track conditions

- Maximum axle load: 30 tons
- Maximum speed: 100 km/h
- Rail inclination: 1:20
- Minimum curve radii: 110 m
- Maximum continuous lateral load: 60 kN
- Maximum lateral load: 80 kN
- Pull-out strength of 50 kN per anchor bolt

QMS SUPPORTING DOCUMENT	DOCUMENT NR: TRL-SPEC-36 (BBH2474)
	VERSION: 1.0
EPOXY (TUNNEL FASTENINGS)	DATE: 2019/05/06
	FILE REF: 16/1/17

6.2.2 Environmental conditions

The product must perform equally well under the following environmental conditions:

- Air temperatures between -10 °C and 50 °C.
- Moderate application temperature (Air and contact surface) between (10 °C and 30 °C)
- Extreme application temperature (Air and contact surface) between (5 °C and 45 °C)
- Arid as well as sub-tropical conditions with high and low humidity levels
- Moist/ damp concrete surfaces
- Fresh, old and less than ideal (i.e. partially dirty, further details can be provided upon request) concrete surfaces
- Within 5 km of the sea.

6.3 Product properties

6.3.1 Freshly mixed properties

Property	Passing criteria	Test method
Pot Life	Minimum 20 minutes @ 40°C ambient temperature.	Epoxy filling ability test TQM-TRL-STM-35
Filling ability	Surface finish: - Surface flatness over rail seat, maximum convexity of 0.5 mm and concavity of 1.0 mm. - Porosity < 10% of the rail seat area - Porosity depth < 4 mm	Epoxy filling ability test TQM-TRL-STM-35
Mixing	Able to mix the sample with a pan mixer, manufacturers specified tools or a static mixer. Visually show that the mix was done correctly.	Epoxy filling ability test TQM-TRL-STM-35
Placement methodology	Must be able to be pumped and poured	Epoxy filling ability test TQM-TRL-STM-35
*Fluidity		Adapted for application:
*Viscosity		

QMS SUPPORTING DOCUMENT	DOCUMENT NR: TRL-SPEC-36 (BBH2474)
	VERSION: 1.0
EPOXY (TUNNEL FASTENINGS)	DATE: 2019/05/06
	FILE REF: 16/1/17

		SANS 5862-1, Concrete tests – Consistence of freshly mixed concrete – Part 1: Slump test
*Passing ability		Adapted for application: BS EN 12350-10
*Segregation		Adapted for application: BS EN 12350-11

* Results will be recorded for future use

6.3.2 Hardened properties

Property	Passing criteria	Test method
*Thermal expansion coefficient		ASTM E831/ ASTM D696/ ISO 11359
Compressive strength	50 MPa Setting time: 2 % compressive strength: 4 hours @ 5°C 10 % compressive strength: 4 hours @ 10°C 100 % compressive strength: 7 days	Adapted for application: SANS 5863
Shrinkage and bond	No visual cracking or separation between epoxy and the concrete core surface after 7 days of curing	Shrinkage and bond test TQM-TRL-STM-36
Dimensional restraints	Minimum thickness: ≥ 5 mm Maximum thickness: ≤ 50 mm	Epoxy filling ability test TQM-TRL-STM-35

* Results will be recorded for future use

QMS SUPPORTING DOCUMENT	DOCUMENT NR: TRL-SPEC-36 (BBH2474)
	VERSION: 1.0
EPOXY (TUNNEL FASTENINGS)	DATE: 2019/05/06
	FILE REF: 16/1/17

6.3.3 In-service properties

Property	Passing criteria	Test method
Slant	No failure of the product and associate components, based on a visual inspection.	TQM-TRL-STM-10 – Slant test
Repeated load		TQM-TRL-STM-11 – Repeated loading
Weathering		TQM-TRL-STM-13 – Weathering test (In track weathering test)
Cast in component		TQM-TRL-STM-22 – Cast in components (Anchoring and bond)
Impact and fracture toughness	Must pass the test without cracking the epoxy after 5 impact tests.	TQM-TRL-STM-17 – Impact and fracture toughness test
Visual inspection	- There are no cracks or shrinkage - The epoxy is still sound	TQM-TRL-STM-20 – Visual inspection
In-service performance	- Installation and in-service tests will be conducted once the product has passed the laboratory test phase. - Period of 1 year - No damage to the system that can be related back to product failure	TQM-TRL-STM-9 – In service test

6.3.4 Durability properties

- Life span of 50 years and
- >1500 MGT

6.3.5 Other properties

- Maintenance free
- Shelf life 12 months

QMS SUPPORTING DOCUMENT	DOCUMENT NR: TRL-SPEC-36 (BBH2474)
	VERSION: 1.0
EPOXY (TUNNEL FASTENINGS)	DATE: 2019/05/06
	FILE REF: 16/1/17

6.3.6 Safety

- It must be safe to use in tunnels with gloves, eye protection and a dust mask

6.4 Experimental components

The product provided must be past the experimental phase and must already be produced to ensure the sustained availability. Upon request the supplier may be required to provide an applicable portfolio of evidence.

6.5 Product labelling

Individual products must be suitably labelled, labelling needs to contain at minimum the following information:

- Product identification
- Manufacturing and expiry date

6.6 Product packaging

Products should be suitably packaged, as individual or multiple units. The following minimum requirements should be met:

- One person must be able to handle the product as packaged. Where it is not possible, due to the size or weight, the supplier must offer alternative methods for handling suitable to the railway environment.
- Packaging should allow for stacking.
- For multiple units packaged together, the package labelling needs to indicate the quantities of each product in addition to the requirements specified in section
- Must be able to use the package supplied for the mixing
- Minimum kit size of 2 litre
- Where possible the product must be colour coded so that it is possible to see that it was mixed properly.

6.7 Warranty

The supplier will be required to guarantee their product against all defects attributable to faulty manufacture and quality of material for a period of two years after the product has been used. The supplier shall be required to replace the defective products, whether discovered pre- or post-use. Transnet will not be responsible to return used stock.

QMS SUPPORTING DOCUMENT	DOCUMENT NR: TRL-SPEC-36 (BBH2474)
	VERSION: 1.0
EPOXY (TUNNEL FASTENINGS)	DATE: 2019/05/06
	FILE REF: 16/1/17

6.8 Disposal

The supplier must in their documentation indicate how the empty containers, mixed and expired products must be disposed of.

7 QUANTITY

As per RFQ.

8 POST PURCHASE SUPPORT

≥ 1 year warranty

9 DOCUMENTATION REQUIRED

9.1 Procurement stage

9.1.1 New products

- Completed Table 1 of this specification.
- Completed RFQ
- The proposal must be specific and include all the required products (e.g. products that may be required for surface preparation or cleaning). The supplier may propose a maximum of two product sets.

9.1.2 Approved products

- Completed Table 1 of this specification.
- Completed RFQ (The quote must include prices for each of the products as outlined in the approval letter separately)
- Letter of approval

9.2 Testing stage

- Handling and storage instructions
- Usage instructions
- Material safety data sheet
- Disposal method/s
- Upon request, the supplier shall supply the following information:
 - Results of relevant previous tests
 - Strength development

QMS SUPPORTING DOCUMENT	DOCUMENT NR: TRL-SPEC-36 (BBH2474)
	VERSION: 1.0
EPOXY (TUNNEL FASTENINGS)	DATE: 2019/05/06
	FILE REF: 16/1/17

- Applicable portfolio of evidence
- Transportation, storing and stacking instructions

9.3 On delivery

Letter of compliance to this specification (issued by the supplier)

10 DELIVERY

Delivery is to be made to the address specified on the relevant purchase document.

11 TIME FRAME

Product delivery required within 30 days after the issue of the purchase order if not mentioned in the RFQ.

12 PRE-APPROVAL AND PRODUCT ASSESSMENT SURVEY

Table 1 below will be used to do the technical product evaluation. The supplier must complete Table 1 as part of their RFQ.

13 ACCEPTANCE CRITERIA

The product or service will be subjected to following checks on delivery to ensure compliance with this specification:

- On receipt of the product it will be checked to ensure that all requirements are met as per Table 2 below.
- If the requirements are not met the product will be returned at the supplier's expense and a refund will be requested.

QMS SUPPORTING DOCUMENT	DOCUMENT NR: TRL-SPEC-36 (BBH2474)
	VERSION: 1.0
EPOXY (TUNNEL FASTENINGS)	DATE: 2019/05/06
	FILE REF: 16/1/17

Table 1: Pre-approval

Description	Compliance criteria	Product specification/ value (to be completed by the supplier)	Internal use
			Pass (Yes/No)
New product			
Details of Product set/s provided (Maximum 2)	Yes		
Currently approves products			
Approval letter supplied	Yes		

Supplier/service approved for purchase: YES/NO			
Supplier/service approved for testing: YES/NO			
Signature of approval personnel		Date	
Name and designation			

QMS SUPPORTING DOCUMENT	DOCUMENT NR: TRL-SPEC-36 (BBH2474)
	VERSION: 1.0
EPOXY (TUNNEL FASTENINGS)	DATE: 2019/05/06
	FILE REF: 16/1/17

Table 2: Delivery checks

Description	Compliance criteria	Internal use
		Pass (Yes/No)
Letter of compliance to this specification supplied	Yes	
Package labelling	Label include Product identification Manufacturing and expiry date	

Supply/service approved: YES/NO			
Signature of approval personnel		Date	
Name and designation			

ANNEXURE B – ECCENTRIC CENTER

Respondent's Signature

Date & Company Stamp

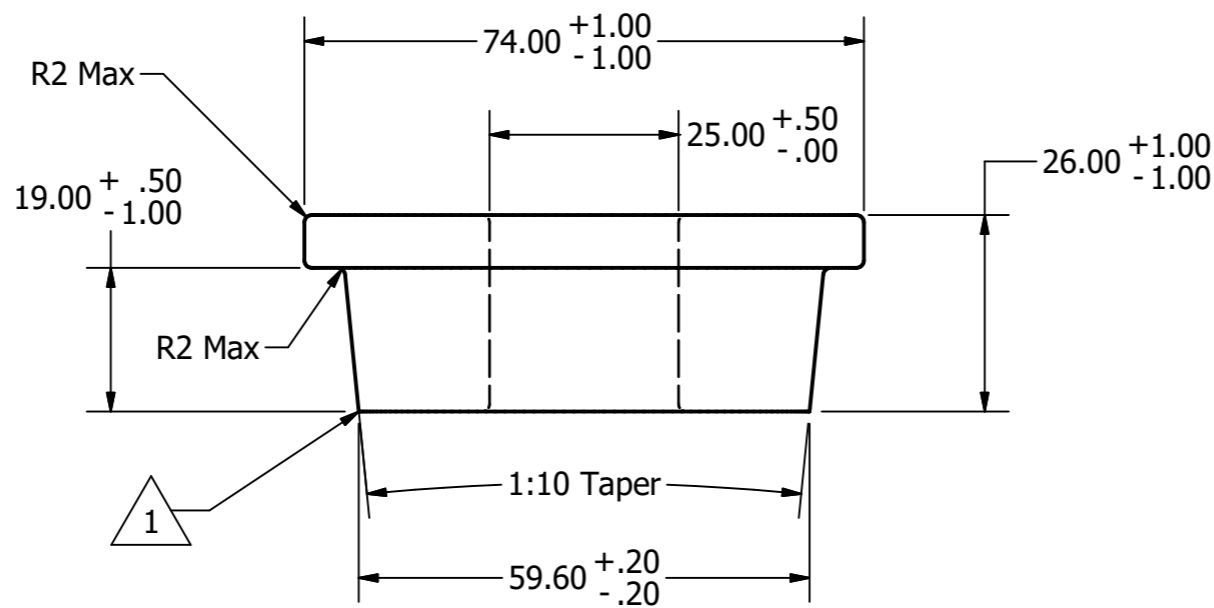
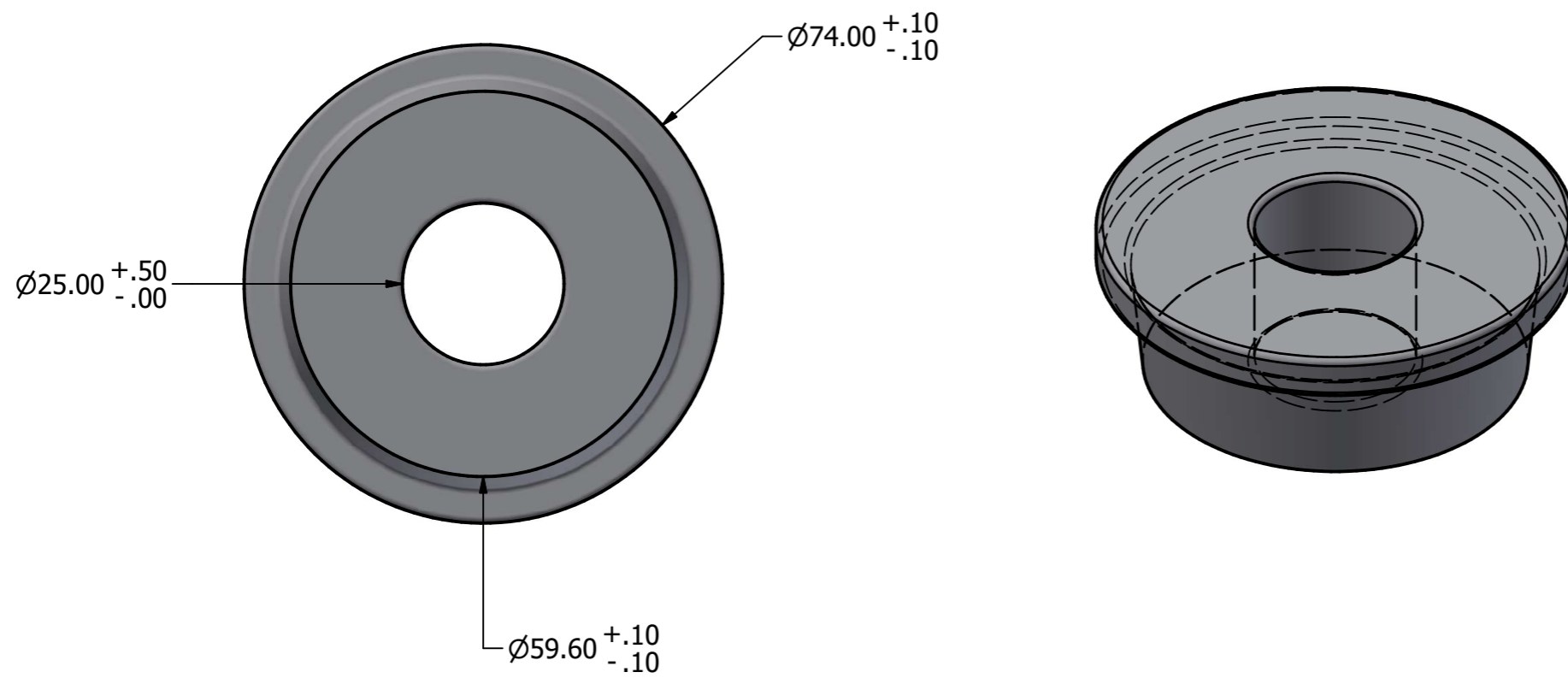

NOTES:

- 1: Remove all sharp edges
 - 2: $0.8\sqrt{\text{All over}}$
 - 3: Zinc diffusion coating class 45+ in accordance with specification SANS 53811 or hot dipped galvanized
 - 4: Tolerances unless otherwise stated
- Two decimal places = ± 0.02
 One decimal place = ± 0.2
 No decimal place = ± 0.5
 Angles = $\pm 0.5^\circ$
5. Material to be Steel

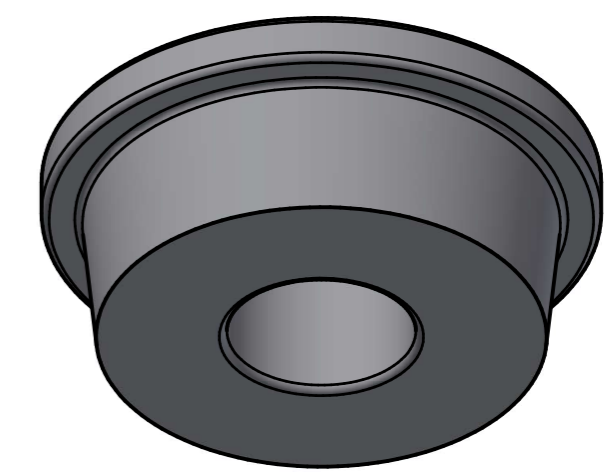

REVISION HISTORY				
ZONE	REV	DESCRIPTION	DATE	APPROVED
1	1	Removed raduis, changed diameter and tolerance on bottom taper.	2018/01/15	
Notes	2	Notes amended	2021/04/21	<i>J.Meyer</i>

DRAWN T.SCHUTTE	DATE 21/04/2021	 TRACK TECHNOLOGY 1 HOUT STREET JEPPESTOWN JOHANNESBURG 2094
CHECKED T.SCHUTTE	DATE 21/04/2021	
APPROVED J.MEYER	DATE 21/04/2021	TITLE E3338 TUNNEL CHAIR COCENTRIC FERRULE
PR REG NO. 9570098	SIGNATURE <i>J.Meyer</i>	SCALE 1:1
<small>COPYRIGHT THIS DRAWING IS THE PROPERTY OF TRANSNET FREIGHT RAIL AND MAY NOT BE REPRODUCED OR GIVEN TO A THIRD PARTY WITHOUT WRITTEN PERMISSION OF TRANSNET FREIGHT RAIL</small>		DWG NO TTC_A263_03
		REV 02

ANNEXURE C – EPOXY PAN MIXER

Respondent's Signature

Date & Company Stamp



QUALITY MANAGEMENT SYSTEM

PAN MIXER FOR MIXING OF EPOXY

SPECIFICATION

Specification number	TRL-Spec-06
Version number	3.0
Compiler name	Rodney Tshisikule
Compiler signature	<i>Tshisikule RR</i>
Approver name	Josia Meyer
Approver signature	<i>J Meyer</i>

QMS SUPPORTING DOCUMENT	DOCUMENT NR: A54
	VERSION: 3.0
PAN MIXER FOR MIXING OF EPOXY	DATE: 2023/04/26
	FILE REF: 16/1/17

TABLE OF CONTENTS

1	Specification version	3
2	Purpose	3
3	Scope of specification.....	3
4	Reference documentation	3
5	Definitions and abbreviations	3
6	Technical requirements	3
7	Quantity.....	4
8	Post purchase support.....	5
9	Documentation required	5
9.1	Procurement stage	5
9.2	On delivery	5
10	Delivery	5
11	Time frame	5
12	Evaluation of suppliers/service providers.....	5
13	Acceptance criteria.....	6

QMS SUPPORTING DOCUMENT	DOCUMENT NR: A54
	VERSION: 3.0
PAN MIXER FOR MIXING OF EPOXY	DATE: 2023/04/26
	FILE REF: 16/1/17

1 SPECIFICATION VERSION

This specification supersedes all previous versions of the specifications for the supply of a pan mixer for the mixing of epoxies.

2 PURPOSE

The purpose of this document is to supply the tenderer with the minimum technical requirements that the pan mixer must comply with.

3 SCOPE OF SPECIFICATION

The scope of this specification is for the supply of a pan mixer for the proper mixing of epoxy.

4 REFERENCE DOCUMENTATION

Drawings of pan mixer and it's components.

5 DEFINITIONS AND ABBREVIATIONS

None.

6 TECHNICAL REQUIREMENTS

The equipment must comply with the requirement as indicated below.

The pan mixer must consist of the following main components:

- Frame, motor, control box with timer including indicators, bucket holder and mixer (arm)

The components must meet the following requirements:

- A pan mixer as per drawing TTC_A425.
- A frame as per drawing TTC_A426.
- A bucket holder and mixer (arm) as per drawing TTC_A427.
- A minimum 550W 220V AC single capacitor electric motor with a gearbox with a speed of between 6 and 10 RPM
- The gearbox must be sealed.
- The capacitor must be protected.

QMS SUPPORTING DOCUMENT	DOCUMENT NR: A54
	VERSION: 3.0
PAN MIXER FOR MIXING OF EPOXY	DATE: 2023/04/26
	FILE REF: 16/1/17

- It must be possible to transport the assembled pan mixer while laying on its side. (e.g. No leaking of gearbox oil)
- The power cable must be:
 - minimum 4 m long
 - heavy duty 2.5 mm² cable
 - with a 3-point rubber plug
- The top of the shaft must have a key with a bucket holder attached to it.
- All electronics and cables must be concealed.
- The control box must:
 - Have two industrial type buttons for the motor (On and Off).
 - Be IP67 rated.
 - Have all the timer electronics, one industrial start button and three 10 mm LEDs that is visible outside in daylight (Red, Green, Amber)
 - The timer electronics must:
 - Be connected to the 220V power supply and work as follow:
 - When the start button is pressed it must light up the Red LED for 3 minutes before switching off the red light and switching on the amber light. The amber light must be on for 90 seconds before switching off the amber light and switching on the green light.
 - The green led must automatically switch off after 30 seconds.
 - When the start button is pressed twice in succession it must restart.
 - On start-up all LEDs must be off.
 - The final layout of the control box with its buttons and timer must be approved by Transnet before manufacturing starts.
- All steel parts must be painted blue or yellow with an industrial paint that is wear, chip and corrosion resistant.
- The machine must be able to thoroughly mix a 3-part epoxy consisting of a base, activator and a coarse sand in the time indicated by the timer.

7 QUANTITY

As indicated in the RFQ.

QMS SUPPORTING DOCUMENT	DOCUMENT NR: A54
	VERSION: 3.0
PAN MIXER FOR MIXING OF EPOXY	DATE: 2023/04/26
	FILE REF: 16/1/17

8 POST PURCHASE SUPPORT

≥ 1 year warranty on timer, gearbox and electric motor.

9 DOCUMENTATION REQUIRED

9.1 Procurement stage

- Completed Error! Reference source not found. of this specification.
- Completed procurement documentation.

9.2 On delivery

The following must be supplied as part of the delivery:

- User manual for the operation of the pan mixer
- Service manual indicating the service intervals and what needs to be serviced

10 DELIVERY

Is delivery required? YES

Equipment is to be delivered to the below delivery address if not specified on the procurement documentation.

Delivery address:

Transnet Freight Rail

Cnr of Hout and Concession Street

Jeppestown

Johannesburg

2094

11 TIME FRAME

The following time frames must be met.

Product delivery required within 6 weeks after the issue of the purchase order if not mentioned in the RFQ

QMS SUPPORTING DOCUMENT	DOCUMENT NR: A54
	VERSION: 3.0
PAN MIXER FOR MIXING OF EPOXY	DATE: 2023/04/26
	FILE REF: 16/1/17

12 EVALUATION OF SUPPLIERS/SERVICE PROVIDERS

Table 1 below will be used to do the technical evaluation. Table 2 will be used to evaluate the service provider. The supplier must complete Table 1 as part of their RFQ. All fields must be yes to pass the evaluations.

13 ACCEPTANCE CRITERIA

The product or service will be subjected to the following checks on delivery to ensure compliance with the specification:

- On receipt of the pan mixer, it will be checked to ensure that the technical requirements are using Table 3 below.
- If the requirements are not met the following will apply:
 - the supplier will be informed that the product/ service does not comply
 - if applicable the product will be returned
 - the supplier will be given two weeks to rectify the non-compliance
 - if the supplier cannot rectify the non-compliance within two weeks from notification the order will be cancelled

QMS SUPPORTING DOCUMENT	DOCUMENT NR: A54
	VERSION: 3.0
PAN MIXER FOR MIXING OF EPOXY	DATE: 2023/04/26
	FILE REF: 16/1/17

Table 1: Technical requirements evaluation sheet (To be completed by the supplier/ Service provider)

Supplier Name:				
Details of instrument offered:				
Nr	Evaluation	Supplier		TTM evaluation
		Requirements of specification	Supplier's response Yes/No	Comply Yes/No
1	Will the pan mixer be built as indicated in drawings? TTC_A425, TTC_A426 and TTC_A427	Compliance with drawing		
2	Will the pan mixer include the following components that comply with the following technical requirements? <ul style="list-style-type: none"> • Bucket holder • Electric motor • Gearbox • Control box Buttons • Environmental resistance • LEDs • Power supply • Timer functionality 	Key mounted to shaft ≥ 550 W 220 V Capacitor protected 6 – 10 RPM Drum rotation Sealed Industrial type (On, Off and Timer start) ≥ IP67 Red, Amber and Green Visible outside in daylight 220 V As specified (Correct timing, led lights and reset)		

QMS SUPPORTING DOCUMENT	DOCUMENT NR: A54
	VERSION: 3.0
PAN MIXER FOR MIXING OF EPOXY	DATE: 2023/04/26
	FILE REF: 16/1/17

3	Transportation	Design allows for transportation of pan mixer on its side		
4	Power cable	≥ 4 m long Heavy duty 2.5 mm ² 3 Point rubber plug		
5	Electronics and cables	Concealed		
6	Paint	Blue/ Yellow, Industrial: wear, chip and corrosion resistant		
Supplier related				
7	Can the product be delivery within 6 weeks after the issue of the purchase order?	Yes		
8	Will the timer, gearbox and electric motor have a warranty of one year.	Yes		

QMS SUPPORTING DOCUMENT	DOCUMENT NR: A54
	VERSION: 3.0
PAN MIXER FOR MIXING OF EPOXY	DATE: 2023/04/26
	FILE REF: 16/1/17

Table 2: Evaluation of Service provider (This table will be completed by the laboratory)

Supplier name:			
Product/ service:			
Compliance criteria	Specification requirement	Pass /comply (Yes/No)	Comments
Did the products/services meet the minimum technical and supplier related requirements as outlined in Table 1	See Table 1 for details		
Supplier can be considered for purchasing of products/ services:		Yes/No	
Date:			
Signature of approval personnel:			
Name and designation:			

QMS SUPPORTING DOCUMENT	DOCUMENT NR: A54
	VERSION: 3.0
PAN MIXER FOR MIXING OF EPOXY	DATE: 2023/04/26
	FILE REF: 16/1/17

Table 3: Checks on receipt of product (To be completed by the laboratory on receipt of instrument-Purchase of a new instrument)

Instrument:		Serial Number:	
Invoice Number:		P.O Number:	
Description	Specification requirement	Value obtained/ Comments	Pass (Yes/No)
Does the components of the pan mixer comply with the drawings?	Assembled pan mixer with all components- Drawing TTC_A425		
	Frame Drawing- TTC_A426		
	Bucket holder and Mixer - Drawing TTC_A427		
Does the pan mixer include the following components that comply with the following technical requirements? <ul style="list-style-type: none"> • Bucket holder • Electric motor • Gearbox • Control box Buttons • Environmental resistance • LEDs • Power supply • Timer functionality 	Key mounted to shaft ≥ 550 W 220 V Capacitor protected 6 – 10 RPM Drum rotation Sealed Industrial type (On, Off and Timer start) ≥ IP67 Red, Amber and Green Visible outside in daylight 220 V As specified (Correct timing, led lights and reset)		

QMS SUPPORTING DOCUMENT	DOCUMENT NR: A54
	VERSION: 3.0
PAN MIXER FOR MIXING OF EPOXY	DATE: 2023/04/26
	FILE REF: 16/1/17

Is the pan mixer transportable on the side?	Design allows for transportation of pan mixer on its side		
Does the power cable comply with the specification?	≥ 4 m long Heavy duty 2.5 mm ² 3 Point rubber plug		
Does electronics and cables comply with the specification?	Concealed		
Does the paint comply with the specification?	Blue/ Yellow Industrial: wear, chip and corrosion resistant		
Does the field by mixing produce a consistent product?	Thoroughly mix a 3-part epoxy.		
Supplier name:			
Service description:			
Delivery Date:	Product approved:	YES	NO
Approve by:	Designation:	Signature	