

CONTROLLED COPY IF STAMPED
 IN RED TRANSNET ENGINEERING
 UITENHAGE
 5/24/2023
 I.D. DRW. SIGN H.M

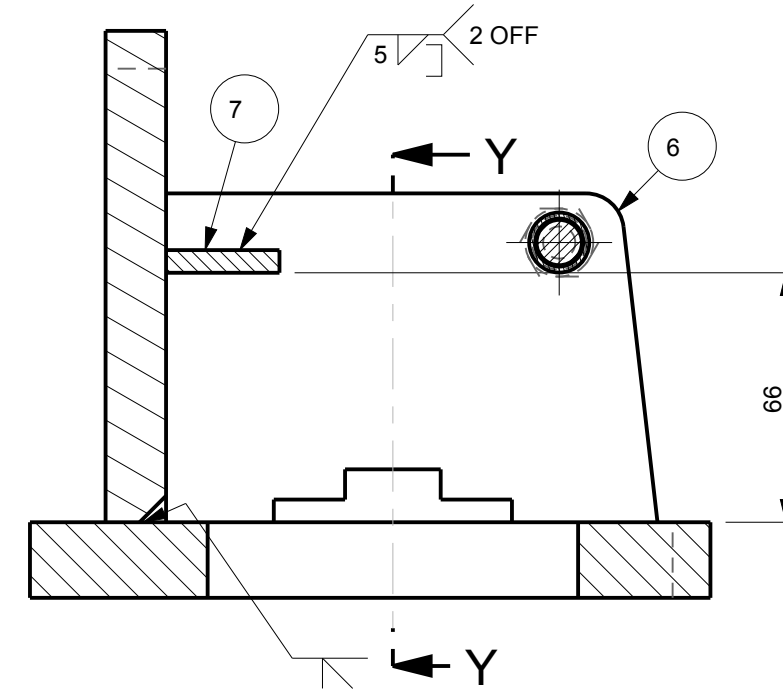

SECTION X-X

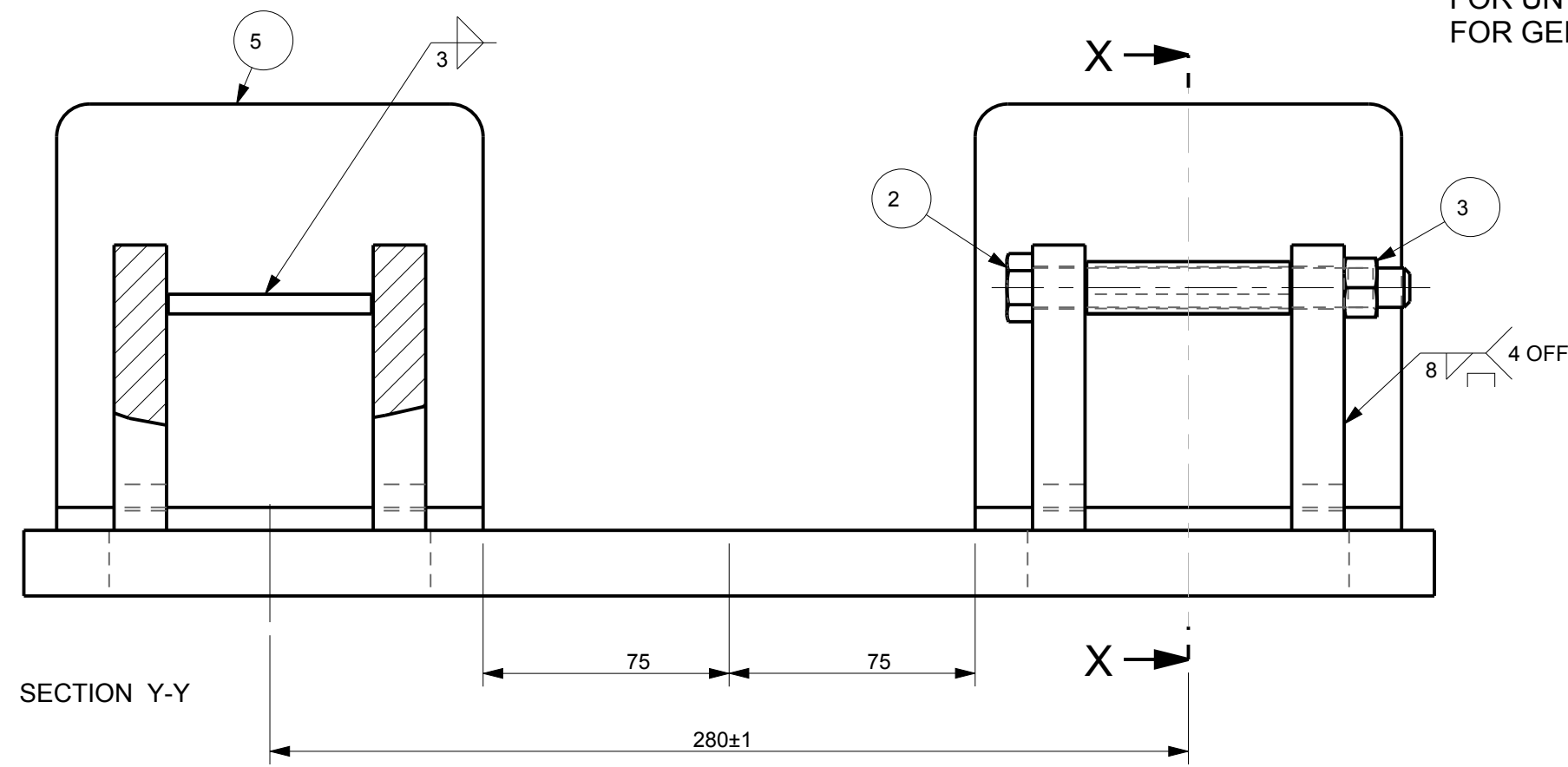
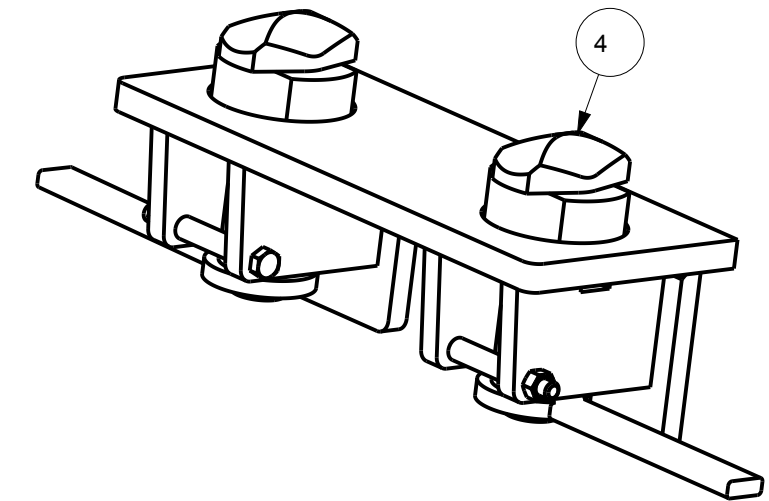

SCALE 1:5

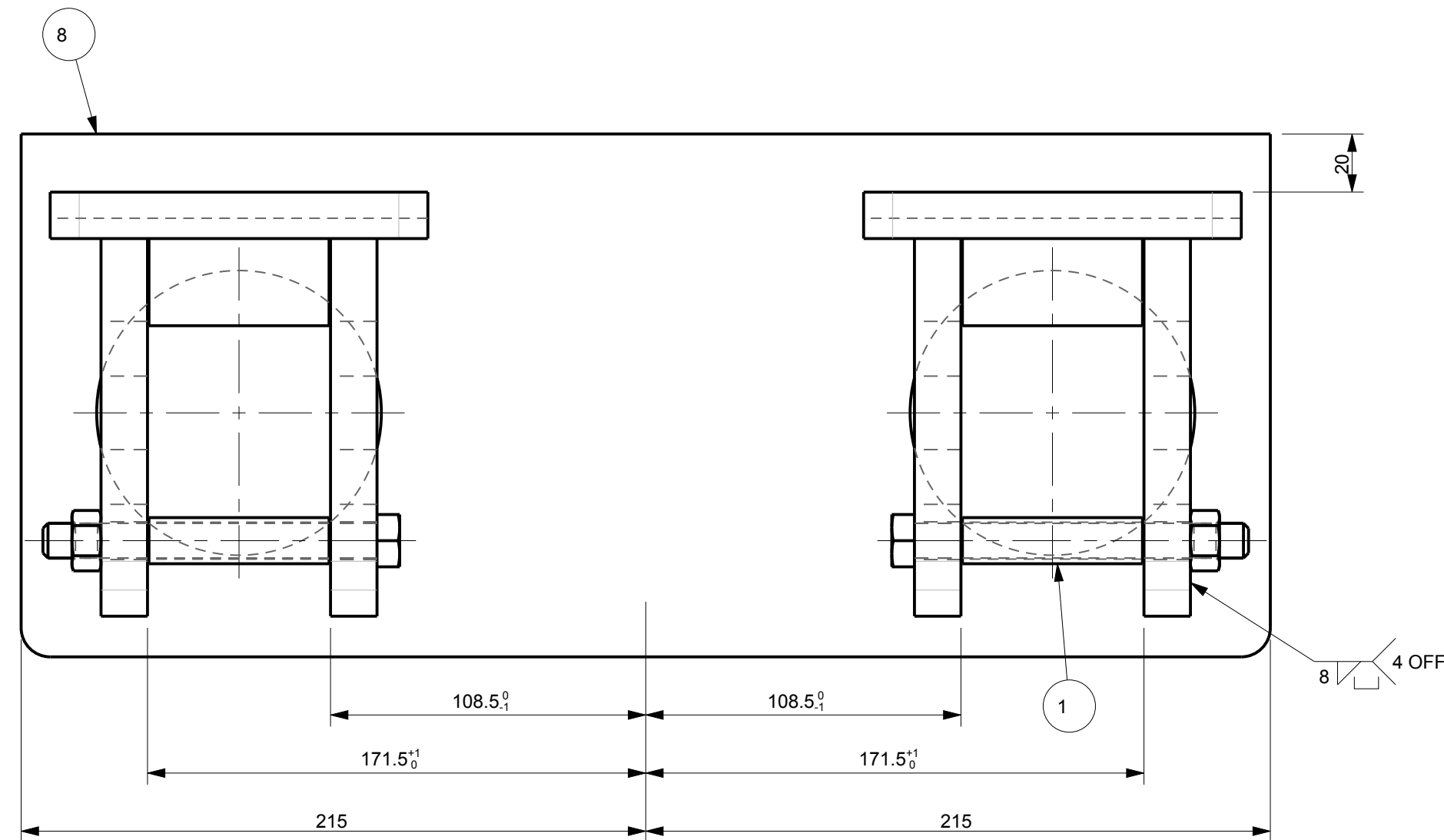

NOTE:

- ITEM 4 OMITTED FOR CLARITY
- ITEM 4 TO BE FITTED BY TWISTLOCK BRACKET MANUFACTURER
- NO WELDING PERMITTED IN HOLE AND LOCKING AREA

ITEM	TITLE	QTY	DRG/PART No.	MATERIAL	SPEC	DESCRIPTION	SIZE	MASS
8	PLATE TOP	1	PEW578B0135					9.78
7	PLATE STOP	2	PEW578B0134					0.09
6	PLATE SIDE	4	PEW578B0133					1.27
5	PLATE BACK	2	PEW578B0132					2.09
4	TWISTLOCK	2	-	STEEL	96/611 ALT 400 R/1	TWISTLOCK		5.46
3	NUT	2	-	STEEL	GRADE 8	M12	M12	0.01
2	BOLT,HEX,BLACK	2	-	STEEL	GRADE 8.8	M12X115	115	0.12
1	STRUCTURAL TUBE	2	-	STEEL	SABS 657	ROUND TUBE DIA 15.8	62	0.03

RENUMBERED FROM
 DRG. BFX3434A_000
 J.v.N 25/10/2011

AMENDMENTS

MASS 30.44 Kg

COPYRIGHT THIS DRAWING TOGETHER WITH THE COPYRIGHT IS THE PROPERTY OF TRANSNET THIS DRAWING OR ANY PART THEREOF IS NOT TO BE COPIED OR OTHERWISE REPRODUCED OR USED FOR MANUFACTURE OR ANY OTHER PURPOSE WITHOUT THE WRITTEN PERMISSION FROM CHIEF EXECUTIVE, TRANSNET RAIL ENGINEERING	ASSEMBLY DRG No.	PEW786B0002	DRAWN	J.v.N	TWISTLOCK,DOUBLE BRACKET FOR CONTAINER WAGON	MATERIAL SEE TABLE
		PEW806B0002	CHECKED	D.C		
	CLASS	SHR-28	APPROVED	D.C		
	TYPE	CONTAINER WAGON	DATE	21/07/2011		
			SCALE	1:2 1:5	SHEET 1 OF 1	
A-2	PROJECTION	DOCUMENT REFERENCE No.			TRANSNET RAIL ENGINEERING	No. PEW578B0137 REV.