

SERVICE AND REPAIR SANDVIK LOADER WHEEL SHOCKS BRAKES X4, DRAWINGS ATTACHED.

1. The Scope of Work

- 1.1. The contractor will have to service all **four** thruster wheel chocks assemblies.
- 1.2. The approved contractor will have to conduct assessment on ship-loader to understand the methodology which will be used to undertake the task.
- 1.3. Park and pin down the ship loader to ensure it is secured during the service of skid brakes. (TPT will assist in parking the ship loader.)
- 1.4. Strip and remove existing brake assemblies on the loader.
- 1.5. Clean, sandblast, treat and paint the area in the loader after removal of the existing brakes.
- 1.6. Take all 4 brakes assemblies to own workshop for repairs.
- 1.7. Replace all the rusted brackets with the new ones on the existing brakes assemblies.
- 1.8. Use 20mm mild steel plates to fabricate and replace rusted brackets.
- 1.9. Replace all stainless-steel pins with the new one for each frame.
- 1.10. Replace with new braking shoes on all brake assemblies.
- 1.11. Sandblast and paint with standard paint colour safety yellow RAL#1006.
- 1.12. Replace with new inductive sensor (sensing range 10mm, 2 wire N/O, 30Vdc, IP67, power LED green, output LED red, vibration and shock resistant).
- 1.13. Install new thruster motors all four brakes.
 - The new thruster wheel chocks must be highly resistant to corrosion.
 - Thruster wheel chocks specification: Voltage 380V- 400V, Frequency 50HZ, thruster model ESCD, Size 080, stroke 060, motor 9wt, example.
 - Type: TWCS-100-ALL (to be conformed onsite in of terms size) – *picture below*

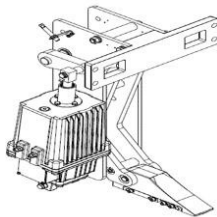

- 1.14. Service the roller which is attached on the Ship loader and ensure it is turning freely.
- 1.15. Service and repair storm lock pins x2, ensure moving freely and re install position sensors.
- 1.16. Housekeeping to be performed in the completion of the project.
- 1.17. Travel the Ship loader the whole berth to check if there is no obstruction on rail.
- 1.18. Function tests the brakes (TPT personnel to assist).

2.2 General Service

- 2.2.1 All Structural components must be fully painted according to Transnet specification.
- 2.2.2 All fasteners on the repaired portion must be HT and hot dip galvanised.

PORT RAIL TERMINALS	SANDVIK THRUSTER WHEEL CHOCKS SERVICE AND REPAIR			RICHARDSBAY PORT RAIL TERMINAL
	SOW	Compiled By: Nombulelo Masuku	Page 1 of 8	

2.2.3 All material must be SABS approved.

NB. Any deviation from this scope should be authorised by TPT management before work can be carried out.

1.3. Specifications

Quality Management Specification for supplier	EEAM-Q-009 (Rev. 0)
Corrosion Protection	EEAM-Q-008 (HE9-2-8 Ver. 17)

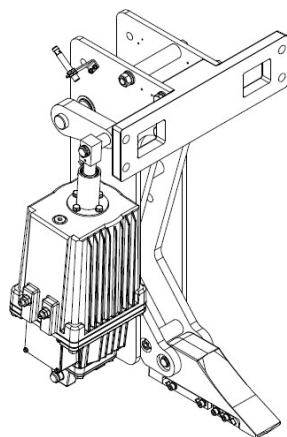

DRAWINGS FOR THRUSTER WHEEL CHOCKS

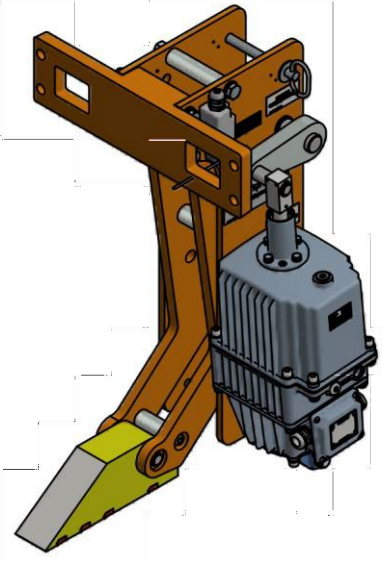
<p style="font-size: 24pt; margin: 0;">Hillmar</p> <p style="margin: 0;">Hillmar Industries Ltd.</p> <p style="font-size: 10pt; margin: 0;">7371 Vantage Way Delta, BC V4G 1C9 P:604 946-7115 F:604 946-0329 info@hillmar.com www.hillmar.com</p>	<p style="margin: 0;">WHEEL CHOCK TWCS TWCS-100-0380-0710-LH SPECIFICATION SHEET SLS & MKTG ENGLISH</p>			<p style="font-size: 10pt; margin: 0;">Sheet Number:</p>																						
				<p style="font-size: 10pt; margin: 0;">Job Number:</p>																						
				<p style="font-size: 10pt; margin: 0;">Form Number: 229-411-41447PT</p>																						
<p style="font-size: 10pt; margin: 0;">Company / Project Reference:</p>		<p style="font-size: 10pt; margin: 0;">Date.:</p>	<p style="font-size: 10pt; margin: 0;">Page.: 1 OF 1</p>	<p style="font-size: 10pt; margin: 0;">Document Package No.:</p>	<p style="font-size: 10pt; margin: 0;">Rev.:</p>																					
<p style="font-size: 10pt; margin: 0;">Inventor Drawing</p> 	<table border="1" style="width: 100%; border-collapse: collapse;"> <thead> <tr style="background-color: #f2f2f2;"> <th style="width: 70%;">FEATURE</th> <th>CODE</th> </tr> </thead> <tbody> <tr> <td>Wheel chock model</td> <td>TWCS</td> </tr> <tr> <td>Size</td> <td>100</td> </tr> <tr> <td>Wheel tread diameter</td> <td>0380-0710</td> </tr> <tr> <td>Model handing</td> <td>LH</td> </tr> </tbody> </table> <table border="1" style="width: 100%; border-collapse: collapse;"> <tr> <td style="width: 70%;">Example for ordering</td> <td>TWCS-100-0380-0710-LH</td> </tr> </table> <table border="1" style="width: 100%; border-collapse: collapse;"> <thead> <tr style="background-color: #f2f2f2;"> <th colspan="2">TECHNICAL DATA</th> </tr> </thead> <tbody> <tr> <td style="width: 70%;">Maximum holding force (kN) (Depending on wheel loading F_w)</td> <td>100</td> </tr> <tr> <td>Wheel tread diameter (mm)</td> <td>380-710</td> </tr> <tr> <td>Wheel diameter</td> <td>W_D</td> </tr> <tr> <td>Wheel load</td> <td>F_w</td> </tr> <tr> <td>Clamping force</td> <td>F_c</td> </tr> </tbody> </table>		FEATURE	CODE	Wheel chock model	TWCS	Size	100	Wheel tread diameter	0380-0710	Model handing	LH	Example for ordering	TWCS-100-0380-0710-LH	TECHNICAL DATA		Maximum holding force (kN) (Depending on wheel loading F_w)	100	Wheel tread diameter (mm)	380-710	Wheel diameter	W_D	Wheel load	F_w	Clamping force	F_c
FEATURE	CODE																									
Wheel chock model	TWCS																									
Size	100																									
Wheel tread diameter	0380-0710																									
Model handing	LH																									
Example for ordering	TWCS-100-0380-0710-LH																									
TECHNICAL DATA																										
Maximum holding force (kN) (Depending on wheel loading F_w)	100																									
Wheel tread diameter (mm)	380-710																									
Wheel diameter	W_D																									
Wheel load	F_w																									
Clamping force	F_c																									

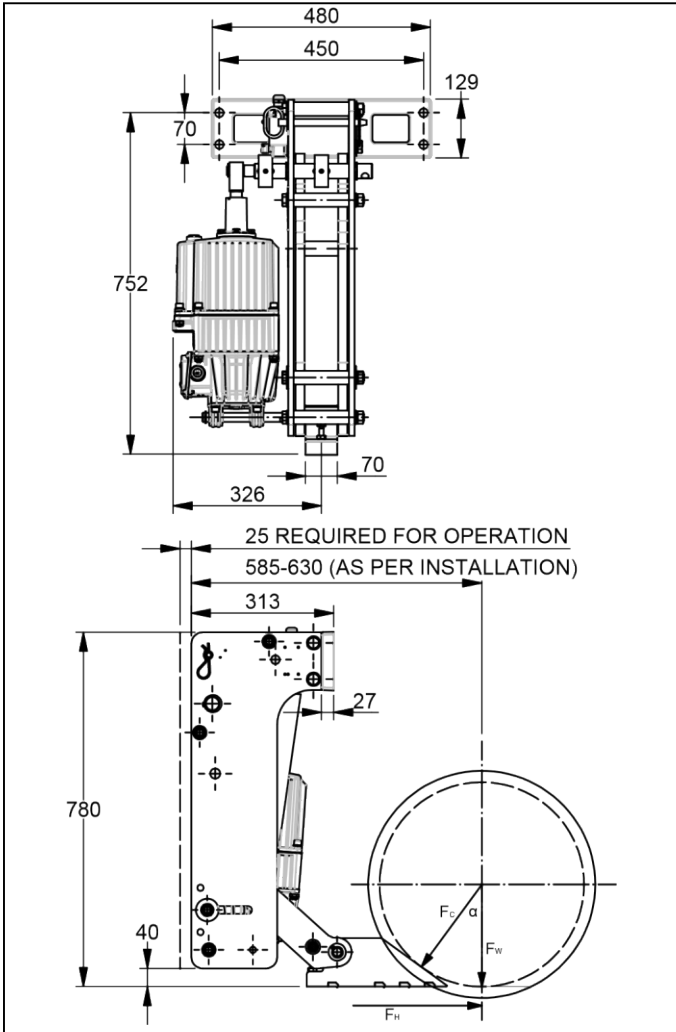

Document Template #710-101-62058

Holding force	F_H
Force angle	$\alpha=36^\circ$
Clamping force calculation	$F_C = F_W \times \cos \alpha$
Holding force calculation	$F_H = F_C \times \mu$
Mounting holes	4 x Ø19
Mounting bolts (CL 10.9)	4 x M16
Standard painting color SAFETY YELLOW	RAL #1006
Weight including thruster (kg)	110

NOMINAL SPECIFICATION

Refer to design kinematic drawing for installation details.
One kinematic drawing is available for each wheel size

NOTES

- All figures are nominal figures only.
- All dimensions are in millimeters.
- International patents apply.

C
-
52

Hillmar

Hillmar Industries
Ltd.

7371 Vantage Way
Delta, BC V4G 1C9
P:604 946-7115 F:604 946-0329
info@hillmar.com www.hillmar.com

WHEEL CHOCK TWCS
TWCS-100-0711-1040-LH
SPECIFICATION SHEET
SLS & MKTG
ENGLISH

Sheet Number:

Job Number:

Form Number:
229-411-41455PT

Company / Project Reference:

Date.:

Page.:
1 OF 1

Document Package No.:

Rev.:

Inventor Drawing

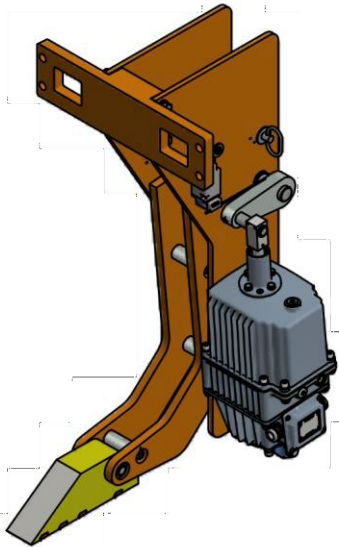

FEATURE	CODE
Wheel chock model	TWCS
Size	100
Wheel tread diameter	0711-1040
Model handing	LH

Example for ordering TWCS-100-0711-1040-LH

TECHNICAL DATA

Maximum holding force (kN) (Depending on wheel loading F_w)	100
Wheel tread diameter (mm)	711-1040
Wheel diameter	W_D
Wheel load	F_w
Clamping force	F_C

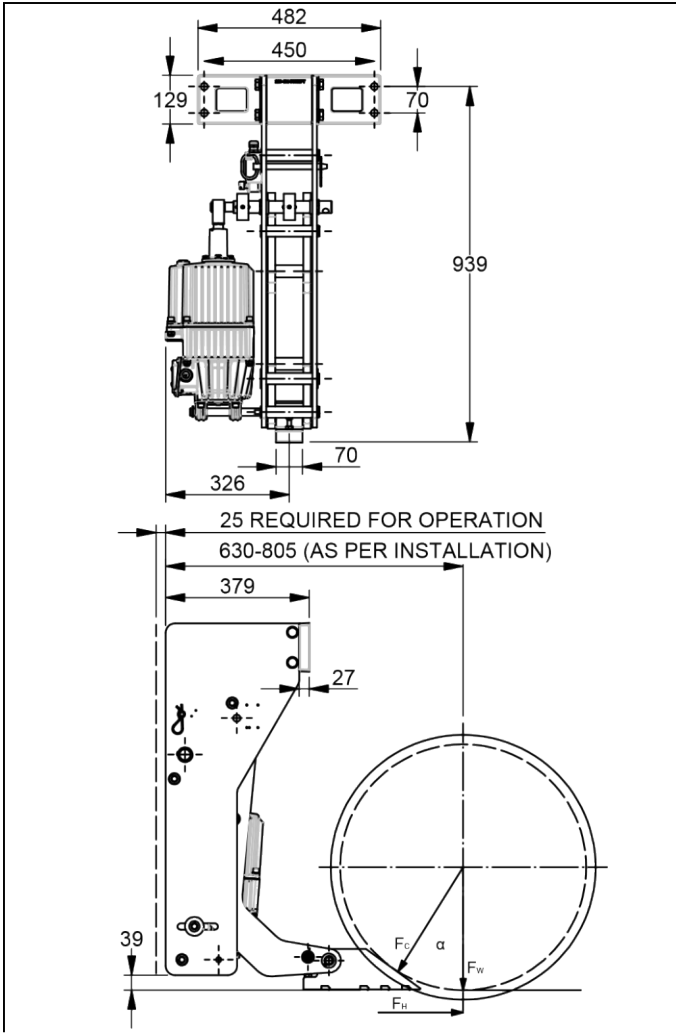

Holding force	F_H
Force angle	$\alpha=36^\circ$
Clamping force calculation	$F_C = F_W \times \cos \alpha$
Holding force calculation	$F_H = F_C \times \mu$
Mounting holes	4 x $\varnothing 19$
Mounting bolts (CL 10.9)	4 x M16
Standard painting color SAFETY YELLOW	RAL #1006
Weight including thruster (kg)	130

NOMINAL SPECIFICATION

Refer to design kinematic drawing for installation details. One kinematic drawing is available for each wheel size

NOTES

- All figures are nominal figures only.
- All dimensions are in millimeters.
- International patents apply.

Document Template #710-101-62058

C
-
52

Hillmar
 Hillmar Industries
 Ltd.
 7371 Vantage Way
 Delta, BC V4G 1C9
 P:604 946-7115 F:604 946-0329
 info@hillmar.com www.hillmar.com

**THRUSTER ESDC
 ESDC-080-060-9WT
 SPECIFICATION SHEET
 SLS & MKTG
 ENGLISH**

Sheet Number:
 Job Number:
 Form Number:
329-321-71785PT
 Document Package No.: Rev.:

Company / Project Reference: Date.: Page.:
 1 OF 1

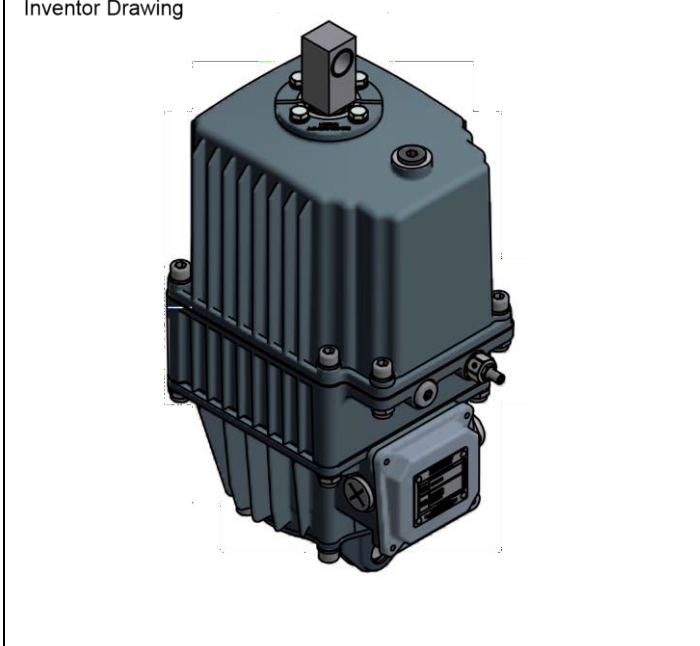

FEATURE	CODE
Thruster model	ESDC
Size	080
Stroke	060
Motor	9WT
Example for ordering	ESDC-080-060-9WT
TECHNICAL DATA	
Nominal force (N)	800
Stroke (mm)	60
Extension time @ nominal force (s)	0.6
Retraction time @ nominal force (s)	0.3
Oil capacity (l)	2.9

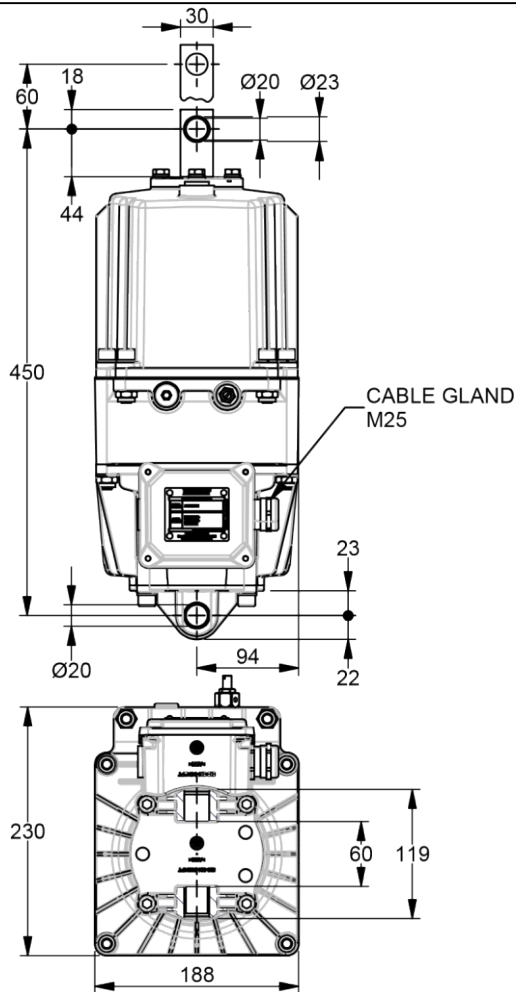

Document Template #710-101-62058

Oil suitable for (°C)	-25 to +60
Oil specifications	HL10 DIN 51524
Electrical specifications	VDE 0530
Insulation class	F
Weight without oil (kg)	22
Design Standard	DIN 15430

NOMINAL SPECIFICATION

In lower range of ambient temperature the lifting times may increase up to four times nominal when unit is operated for first time.

Motor current may increase 1-5 times nominal @ TEMP 0-25 °C

Operating temperature below -25 °C space heater required.

Top pressure clevis is rotatable on all models.

NOTES

All figures are nominal figures only.

All dimensions are in millimeters.

Standard finish anodized clear.

For standard options refer to product configuration sheet.

CT TO CHANGE WITHOUT NOTICE **
 -2008 quality assurance programme (QCB #01-525)